

## 3.0V~5.5V,±15KV ESD-Protected, Fail-safe,Hot-Swap,RS-485RS-422 Transceivers

### ■ Description

The TK13085 3.0~5.5V,+15kV ESD-protected,RS-485/RS-422 transceiver features one driver and one receiver.The device includes fail-safe circuitry, guaranteeing a logic-high receiver output when receiver inputs are open or shorted. The receiver outputs a logic-high if all transmitters on a terminated bus are disabled (high impedance). The TK13085 includes a hot-swap capability to eliminate false transitions on the bus during power-up or hot insertion.The TK13085 features reduced slew-rate drivers that minimize EMI and reduce reflections caused by improperly terminated cables, allowing error-free data transmission up to 1Mbps.

The TK13085 is ideal for half-duplex communications and it draws 0.5mA of supply current when unloaded or when fully loaded with the drivers disabled. The TK13085 has a 1/8-unit load receiver input impedance, allowing up to 256 transceivers on the bus.The TK13085 is available in an 8-pin SOIC packages.

### ■ Features

- Extended ESD Protection for RS-485/RS-422 I/O Pins
- True Fail-Safe Receiver While Maintaining EIA/TIA-485 Compatibility
- Hot-Swap Input Structures on DE and  $\overline{RE}$
- Enhanced Slew-Rate Limiting Facilitates Error- Free Data Transmission
- Low-Current Shutdown Mode
- Allow Up to 256 Transceivers on the Bus
- Available in Industry-Standard 8-Pin SO Packages
- 3.0~5.5V Operation
- Enhanced ESD Specifications: ("F" only)  
 ±15kV IEC61000-4-2 Air Discharge  
 ±8kV IEC61000-4-2 Contact Discharge

### ■ Ordering Information

Part Number	Package	Packaging	Temperature(TA)	Package Qty	Remark
TK13085ESR	SOIC8	Reel	-40°C ~ 85°C	2500	
TK13085ETR	TSSOP8	Reel	-40°C ~ 85°C	2500	
TK13085FSR	SOIC8	Reel	-40°C ~ 85°C	2500	±15KV
TK13085FTR	TSSOP8	Reel	-40°C ~ 85°C	2500	±15KV

Note: Please contact us to customize DIP or other packaging device.

## ■ Pin Description

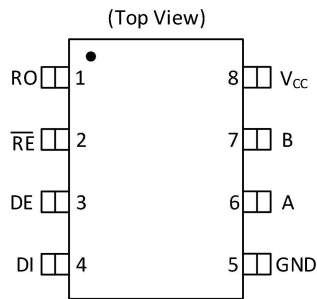

SOIC8 TSSO 8

Table 1. Pin Description

Pin		Description
Name	No.	
RO	1	Receiver Output. When $\overline{RE}$ is low and if $(A-B) \geq -50\text{mV}$ , RO is high; if $(A-B) \leq -200\text{mV}$ , RO is low.
$\overline{RE}$	2	Receiver Output Enable. Drive $\overline{RE}$ low to enable the RO; Drive $\overline{RE}$ high to let the RO in high-impedance; Drive $\overline{RE}$ high and DE low to enter low-power shutdown mode. $\overline{RE}$ is a Hot-swap input (see the Hot-Swap Capability section for details).
DE	3	Driver Output Enable. Drive DE high to enable driver outputs; These outputs are high-impedance when DE is low; Drive $\overline{RE}$ high and DE low to enter low-power shutdown mode. DE is a hot-swap input (see the Hot-Swap Capability section for details).
DI	4	Driver Input. With DE high, a low on DI forces noninverting output low and inverting output high. Similarly, a high on DI forces noninverting output high and inverting output low.
GND	5	Ground
A	6	Noninverting Receiver Input and Noninverting Driver Output
B	7	Inverting Receiver Input and Inverting Driver Output
V <sub>CC</sub>	8	Positive Supply V <sub>CC</sub> = 3.0~5.5V. Bypass V <sub>CC</sub> to GND with a 0.1 $\mu\text{F}$ capacitor.

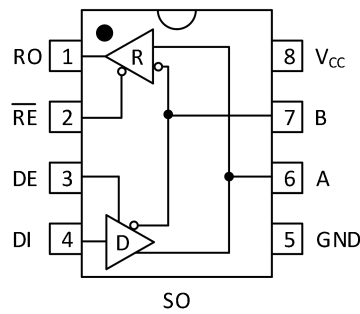
**FUNCTION TABLES**

TRANSMITTING				
INPUTS			OUTPUTS	
DI	DE	$\overline{RE}$	A	B
1	1	X	1	0
0	1	X	0	1
X	0	0	Z	Z
X	0	1	Shutdown	
RECEIVING				
INPUTS			OUTPUTS	
$\overline{RE}$	DE	A - B	RO	
0	X	$\geq -50\text{mV}$	1	
0	X	$\leq -200\text{mV}$	0	
0	X	Open/Shorted	1	
1	1	X	Z	
1	0	X	Shutdown	

**ABSOLUTE MAXIMUM RATINGS**

Parameter	Parameter	Rating	UNIT
$V_{CC}$	Supply Voltage	+6	V
$\overline{RE}, DE$	Control Input Voltage	-0.3 to +6	V
DI	Driver Input voltage	-0.3 to +6	V
A,B	Receiver Input Voltage	-8V to $\pm 13$	V
A,B	Driver Output Voltage	-8V to $\pm 13$	V
RO	Receiver Output Voltage	-0.3 to ( $V_{CC}+0.3$ )	V
P	SO(derate 5.9mW/°C above +70°C)	471	mW
$T_{OP}$	Operating Temperature Range	-40 to +85	°C
$T_J$	Junction Temperature	+150	°C
$T_{STO}$	Storage Temperature Range	-65 to +150	°C
$T_L$	Lead Temperature(soldering,10s)	+300	°C

Stresses beyond those listed under "Absolute Maximum Ratings" may cause permanent damage to the device. These are stress ratings only, and functional operation of the device at these or any other conditions beyond those indicated in the operational sections of the specifications is not implied. Exposure to absolute maximum rating conditions for extended periods may affect device reliability.

**DC ELECTRICAL CHARACTERISTICS**

 (V<sub>CC</sub> = 5V ±5%, T<sub>A</sub> = T<sub>MIN</sub> to T<sub>MAX</sub>. Typical values are at V<sub>CC</sub>=+5V, T<sub>A</sub>=25°C, unless otherwise noted.)<sup>(1)</sup>

Parameter	Symbol	Test Conditions	MIN	TYP	MAX	UNIT
<b>Driver</b>						
Supply voltage	V <sub>CC</sub>		4.5		5.5	V
Differential Driver Output(No load)	V <sub>OD1</sub>	No load			V <sub>CC</sub>	V
Differential Driver Output	V <sub>OD2</sub>	RL=100Ω(RS-422),Figure 1	3		V <sub>CC</sub>	V
		RL=54Ω(RS-485),Figure 1	2		V <sub>CC</sub>	V
Change in Magnitude of Differential Output Voltage <sup>(2)</sup>	ΔV <sub>OD</sub>	RL=100Ω or RL=54Ω,Figure 1			0.2	V
Driver Common- Mode Output Voltage	V <sub>OC</sub>	RL=100Ω or RL=54Ω,Figure 1		V <sub>CC</sub> /2	3	V
Change in Magnitude of Common- Mode Voltage <sup>(2)</sup>	ΔV <sub>OC</sub>	RL=100Ω or RL=54Ω,Figure 1			0.2	V
Input-High Voltage	V <sub>IH1</sub>	DE,DI, $\overline{RE}$	3			V
Input-Low Voltage	V <sub>IL1</sub>	DE,DI, $\overline{RE}$			0.8	V
Input Hysteresis	V <sub>HYS</sub>	DE,DI, $\overline{RE}$		300		mV
Input Current	I <sub>IN1</sub>	DE,DI, $\overline{RE}$ , V <sub>CC</sub> floating			±2	μA
Input Impedance on First Transition at Power-Up	R <sub>PWUP</sub>	V <sub>DE</sub> , V <sub>RE</sub> = V <sub>RE</sub> = 2V	3.65		8.8	kΩ
Input Impedance on First Transition after POR Delay	R <sub>ft</sub>	V <sub>DE</sub> = V <sub>RE</sub> = 2V	7		60	kΩ
Driver Short-Circuit Output Current	I <sub>OSD</sub>	0≤V <sub>OUT</sub> ≤+12V <sup>(3)</sup>	40		250	mA
		-7V≤V <sub>OUT</sub> ≤V <sub>CC</sub> <sup>(3)</sup>	-250		-40	
Driver Short-Circuit Foldback Output Current	I <sub>OSDF</sub>	(V <sub>CC</sub> -1V)≤V <sub>OUT</sub> ≤+12V <sup>(3)</sup>	20			mA
		-7V≤V <sub>OUT</sub> ≤±1V <sup>(3)</sup>			-20	
Thermal-Shutdown Threshold	T <sub>TS</sub>			175		°C
Thermal-Shutdown Hysteresis	T <sub>TSH</sub>			15		°C
Input Current for A and B	I <sub>A,B</sub>	DE=GND, V <sub>CC</sub> =GND or V <sub>CC</sub>	V <sub>IN</sub> =+12V		100	μA
			V <sub>IN</sub> =-7V	-100		
<b>Receiver</b>						
Receiver Differential Threshold Voltage	V <sub>TH</sub>	-7V≤V <sub>CM</sub> ≤12V	-200	-125	-50	mV
Receiver Input Hysteresis	ΔV <sub>TH</sub>	V <sub>A</sub> +V <sub>B</sub> =0V		15		mV
Receiver Output-High Voltage	V <sub>OH</sub>	I <sub>O</sub> = -1mA		V <sub>CC</sub> -0.6	V <sub>CC</sub>	V
Receiver Output-Low Voltage	V <sub>OL</sub>	I <sub>O</sub> = 1mA			0.4	V
Three-State Output Current at Receiver	I <sub>OZR</sub>	0V≤V <sub>O</sub> ≤V <sub>CC</sub>			≤1	μA
Receiver Input Resistance	R <sub>IN</sub>	-7V≤V <sub>CM</sub> ≤12V	96			kΩ
Receiver Output Short-Circuit Current	I <sub>OSR</sub>	0V≤V <sub>RO</sub> ≤V <sub>CC</sub>			≤110	mV
<b>Supply Current</b>						
Supply current	I <sub>CC</sub>	No load, $\overline{RE}$ =GND DE=V <sub>CC</sub>		0.5	0.7	mA
		No load, $\overline{RE}$ =V <sub>CC</sub> , DE=V <sub>CC</sub>		0.5	0.7	
		No load, $\overline{RE}$ =GND DE=GND		0.5	0.7	
Supply Current in Shutdown Mode	I <sub>SHDN</sub>	$\overline{RE}$ =GND DE=GND		2.0	10	μA
<b>ESD Protection</b>						
ESD Protection (A, B)	ESD	Human Body Mode		±15		kV
		Contact Discharge IEC 61000-4-2		±8		kV
		Air-Gap Discharge IEC 61000-4-2		±15		

### DRIVER SWITCHING CHARACTERISTICS WITH INTERNAL SRL(500KBPS)

( $V_{CC}=+5V\pm 10\%$ ,  $T_A=T_{MIN}-T_{MAX}$ , Typical values are at  $V_{CC}=+5V$  and  $T_A=25^\circ C$ ; unless otherwise noted.<sup>(1)</sup>)

Parameter	Symbol	Conditions	MIN	TYP	MAX	UNITS
Driver Propagation Delay	$t_{DPLH}$	$R_L=54\Omega, C_L=50pF$ , Figure 2 and Figure 3	200		1000	ns
	$t_{DPHL}$		200		1000	
Driver Output Skew $ t_{DPLH} - t_{DPHL} $	$t_{DHKEW}$	$R_L=54\Omega, C_L=50pF$ , Figure 2 and Figure 3			140	ns
Driver Differential Output Rise or Fall Time	$t_R, t_F$	$R_L=54\Omega, C_L=50pF$ , Figure 2 and Figure 3	100		500	ns
Maximum Data Rate	$F_{MAX}$		1000			kbps
Driver Enable to Output High	$t_{DZH}$	Figure 4			2500	ns
Driver Enable to Output Low	$t_{DZL}$	Figure 5			2500	ns
Driver Disable Time from Low	$t_{DLZ}$	Figure 5			100	ns
Driver Disable Time from High	$t_{DHZ}$	Figure 4			100	ns
Driver Enable from Shutdown to Output High	$t_{DZH(SHDN)}$	Figure 4			5500	ns
Driver Enable from Shutdown to Output Low	$t_{DZL(SHDN)}$	Figure 5			5500	ns
Time to Shutdown	$t_{SHDN}$		50	340	700	ns

### RECEIVER SWITCHING CHARACTERISTICS WITH INTERNAL SRL(500KBPS)

( $V_{CC}=+5V\pm 10\%$ ,  $T_A=T_{MIN}-T_{MAX}$ , Typical values are at  $V_{CC}=+5V$  and  $T_A=25^\circ C$ ; unless otherwise noted.<sup>(1)</sup>)

Parameter	Symbol	Conditions	MIN	TYP	MAX	UNITS
Receiver Propagation Delay	$t_{RPLH}$	$C_L=15pF$ , Figure 6 and Figure 7			200	ns
	$t_{RPHL}$				200	
Receiver Output Skew $ t_{DPLH} - t_{DPHL} $	$t_{RSKEW}$	$C_L=15pF$ , Figure 6 and Figure 7			30	ns
Maximum Data Rate	$F_{MAX}$		1000			kbps
Receiver Enable to Output Low	$t_{RZL}$	Figure 8			50	ns
Receiver Enable to Output High	$t_{RZH}$	Figure 8			50	ns
Receiver Disable Time from Low	$t_{RLZ}$	Figure 8			50	ns
Receiver Disable Time from High	$t_{RHZ}$	Figure 8			50	ns
Receiver Enable from Shutdown to Output High	$t_{RZH(SHDN)}$	Figure 8			3500	ns
Receiver Enable from Shutdown to Output Low	$t_{RZL(SHDN)}$	Figure 8			3500	ns
Time to Shutdown	$t_{SHDN}$		50	340	700	ns

1. All currents into the device are positive. All currents out of the device are negative. All voltages are referred to device ground, unless otherwise noted.

2.  $\Delta V_{OD}$  and  $\Delta V_{OC}$  are the changes in  $V_{OD}$  and  $V_{OC}$ , respectively, when the DI input changes state.

3. The short-circuit output current applies to peak current just prior to foldback current limiting. The short-circuit foldback output current applies during current limiting to allow a recovery from bus contention.

■ **TEST CIRCUITS AND WAVEFORMS**

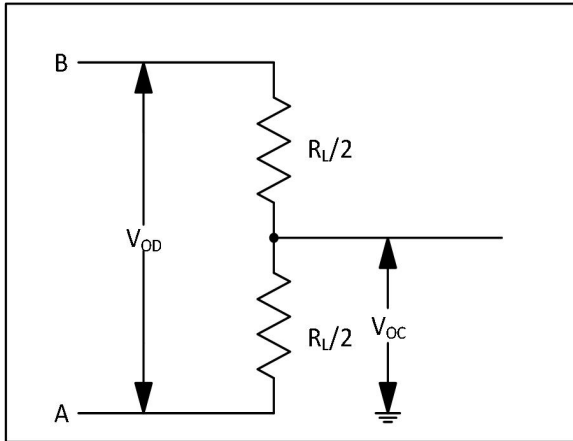

**Figure 1. Driver DC Test Load**

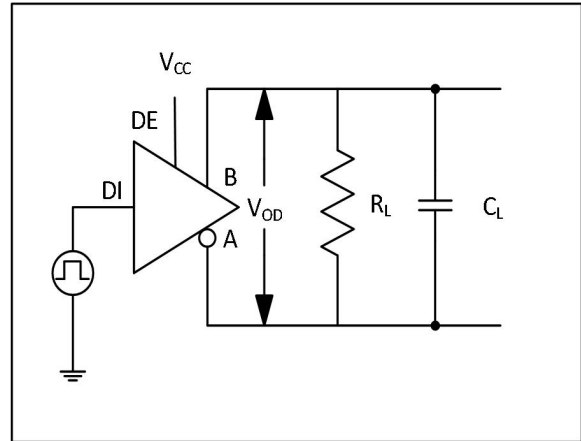

**Figure 2. Driver timing test load**

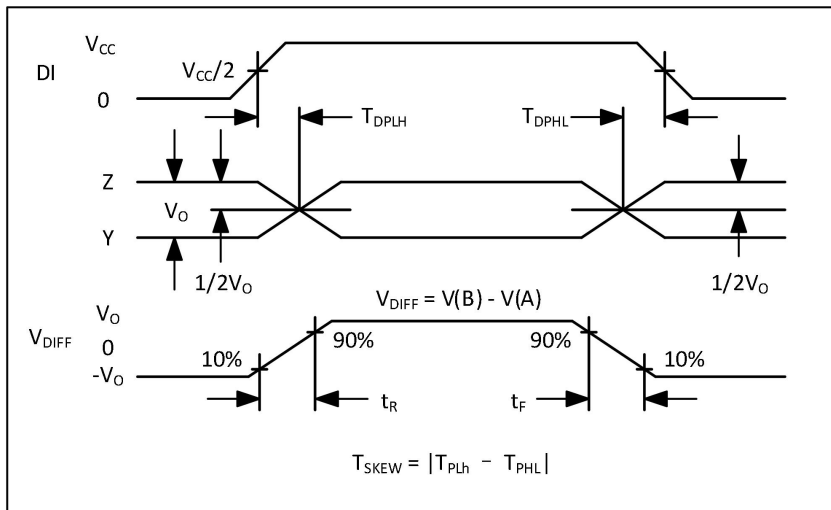

**Figure 3. Driver Propagation Delays**

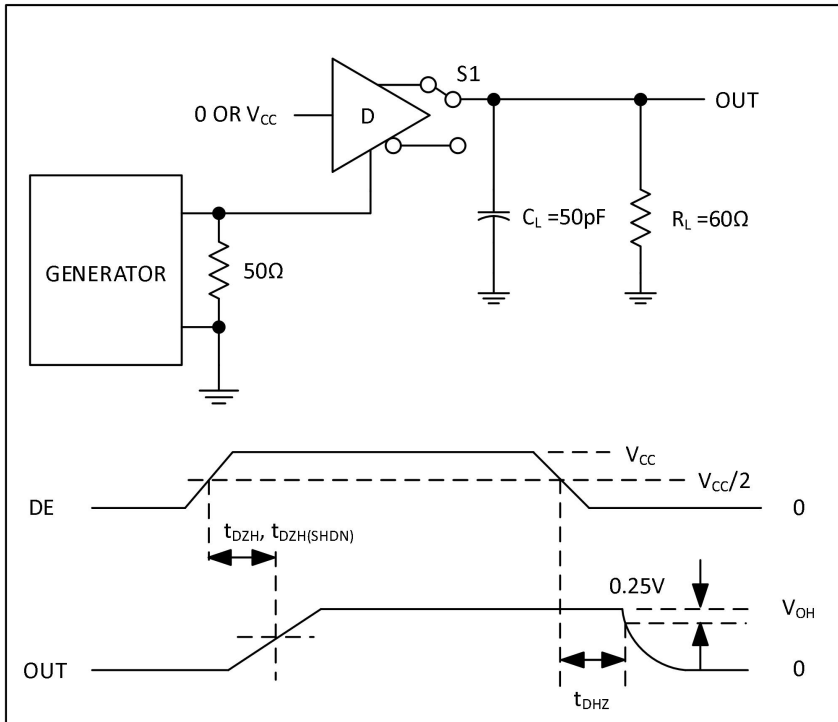

Figure 4. Driver Enable and Disable Times ( $t_{DHL}$ ,  $t_{DZH}$ ,  $t_{DZH(SHDN)}$ )

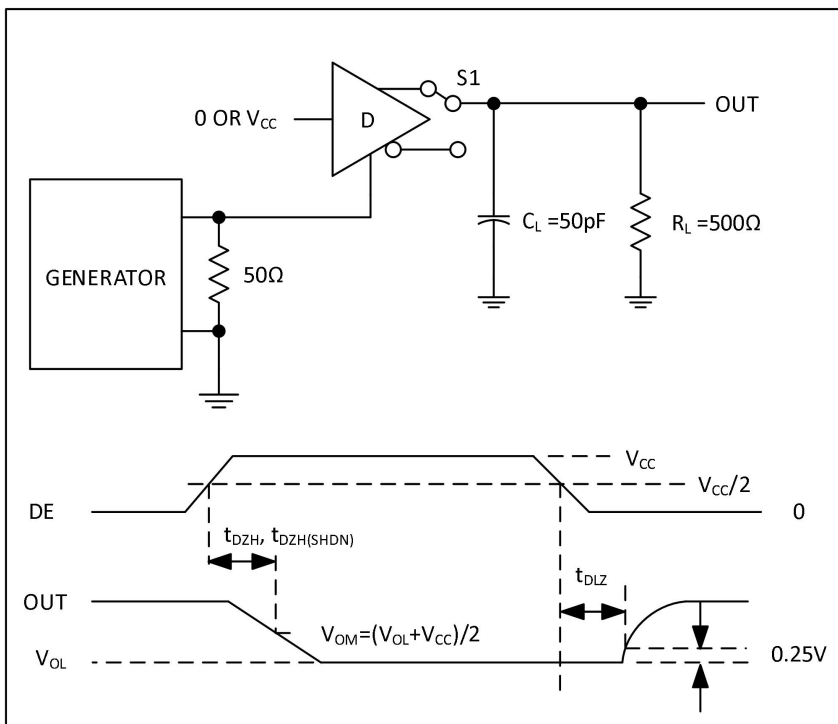

Figure 5. Driver Enable and Disable Times ( $t_{DZL}$ ,  $t_{DLZ}$ ,  $t_{DLZ(SHDN)}$ )

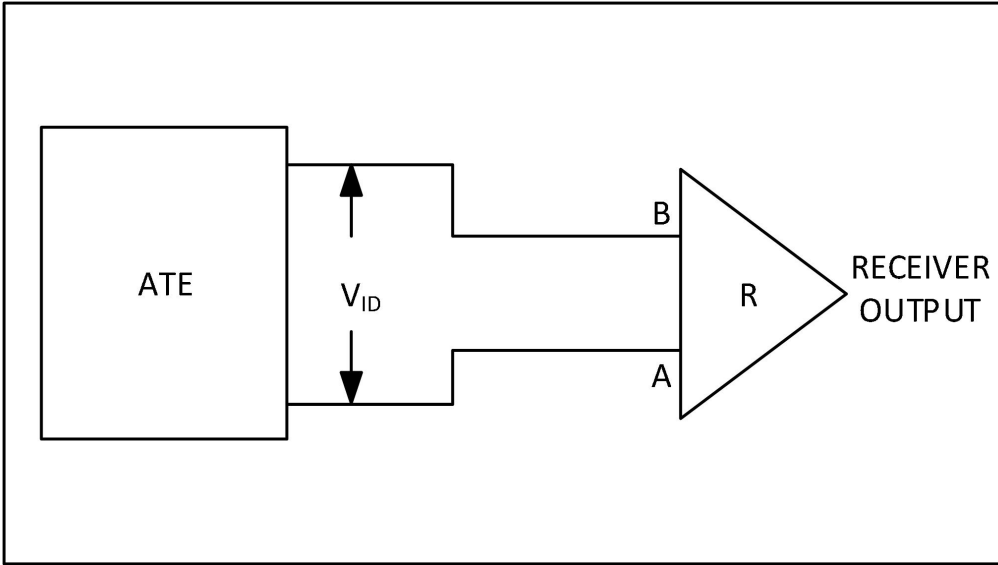

Figure 6. Receiver Propagation Delay Test Circuit

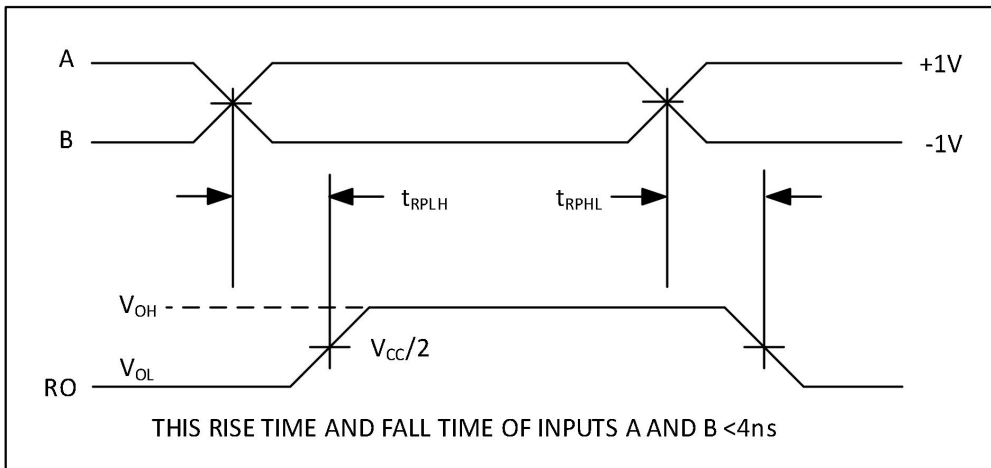
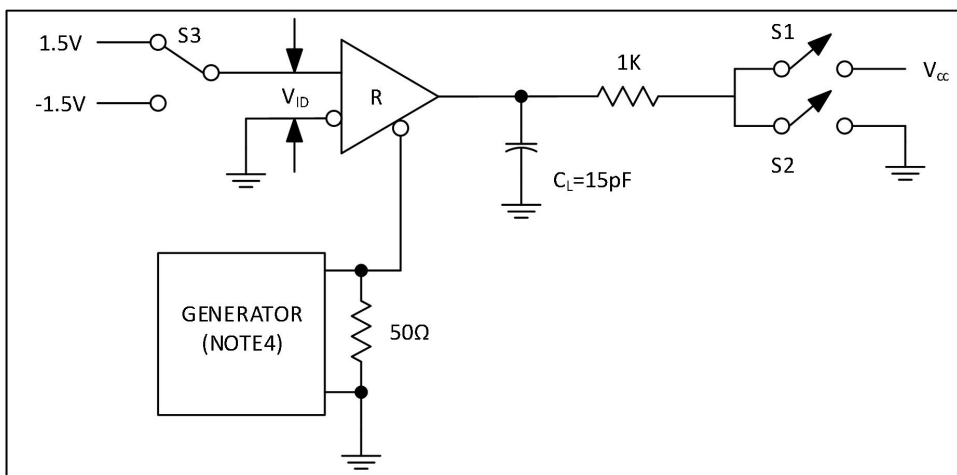
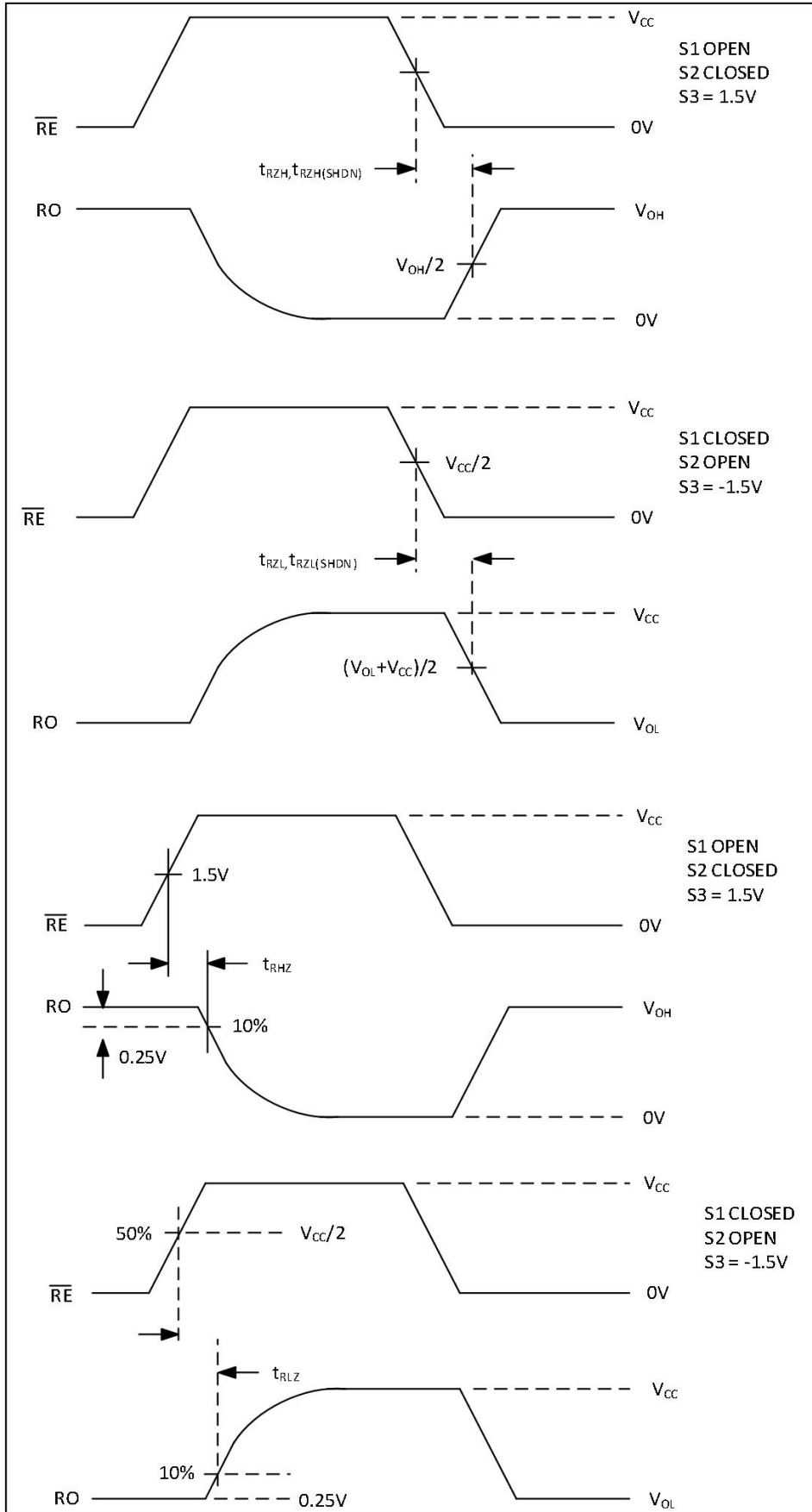

Figure 7. Receiver Propagation Delays





**Figure 8. Receiver Enable and Disable Times**

## ■ DETAILED DESCRIPTION

The TK13085 high-speed transceiver for RS-485/RS-422 communication contains one driver and one receiver. This device features fail-safe circuitry, which guarantees a logic-high receiver output when the receiver inputs are open or shorted, or when they are connected to a terminated transmission line with all drivers disabled (see the Fail-Safe section). The TK13085 also features a hot-swap capability allowing line insertion without erroneous data transfer (see the Hot-Swap Capability section). The TK13085 features reduced slew-rate drivers that minimize EMI and reduce reflections caused by improperly terminated cables, allowing error-free data transmission up to 1Mbps. The TK13085 is a half-duplex transceiver and operates from a single +3.0~5.5V supply. Drivers are output short-circuit current limited. Thermal-shutdown circuitry protects drivers against excessive power dissipation. When activated, the thermal-shutdown circuitry places the driver outputs into a high-impedance state.

### Fail-Safe

The TK13085 guarantees a logic-high receiver output when the receiver inputs are shorted or open, or when they are connected to a terminated transmission line with all drivers disabled. This is done by setting the receiver input threshold between -50mV and -200mV. If the differential receiver input voltage (A - B) is greater than or equal to -50mV, RO is logic-high. If (A - B) is less than or equal to -200mV, RO is logic-low. In the case of a terminated bus with all transmitters disabled, the receiver's differential input voltage is pulled to 0V by the termination. With the receiver threshold of the TK13085, this results in a logic-high with a 50mV minimum noise margin. Unlike previous fail-safe devices, the -50mV to -200mV threshold complies with the  $\pm 200\text{mV}$  EIA/TIA-485 standard.

### Hot-Swap Capability

#### Hot-Swap Inputs

When circuit boards are inserted into a hot or powered backplane, differential disturbances to the data bus can lead to data errors. Upon initial circuit board insertion, the data communication processor undergoes its own power-up sequence. During this period, the processor's logic-output drivers are high impedance and are unable to drive the DE and RE inputs of these devices to a defined logic level. Leakage currents up to  $\pm 10\mu\text{A}$  from the high-impedance state of the processors logic drivers could cause standard CMOS enable inputs of a transceiver to drift to an incorrect logic level. Additionally, parasitic circuit board capacitance could cause coupling of  $V_{CC}$  or GND to the enable inputs. Without the hot-swap capability, these factors could improperly enable the transceiver's driver or receiver. When  $V_{CC}$  rises, an internal pulldown circuit holds DE low and RE high. After the initial power-up sequence, the pulldown circuit becomes transparent, resetting the hot-swap tolerable input.

#### Hot-Swap Input Circuitry

The enable inputs feature hot-swap capability. At the input there are two nMOS devices, M1 and M2 ([Figure 9](#)).

When  $V_{CC}$  ramps from zero, an internal  $7\mu\text{s}$  timer turns on M2 and sets the SR latch, which also turns on M1.

Transistors M2, a  $500\mu\text{A}$  current sink, and M1, a  $100\mu\text{A}$  current sink, pull DE to GND through a  $5\text{k}\Omega$  resistor. M2 is designed to pull DE to the disabled state against an external parasitic capacitance up to  $100\text{pF}$  that can drive DE high.

After  $7\mu\text{s}$ , the timer deactivates M2 while M1 remains on, holding DE low against three-state leak ages that can drive DE high. M1 remains on until an external source overcomes the required input current. At this time, the SR latch resets and M1 turns off.

When M1 turns off, DE reverts to a standard, high-impedance CMOS input. Whenever  $V_{CC}$  drops below  $1\text{V}$ , the hot swap input is reset. For RE there is a complementary circuit employing two pMOS devices pulling  $\overline{\text{RE}}$  to  $V_{CC}$ .

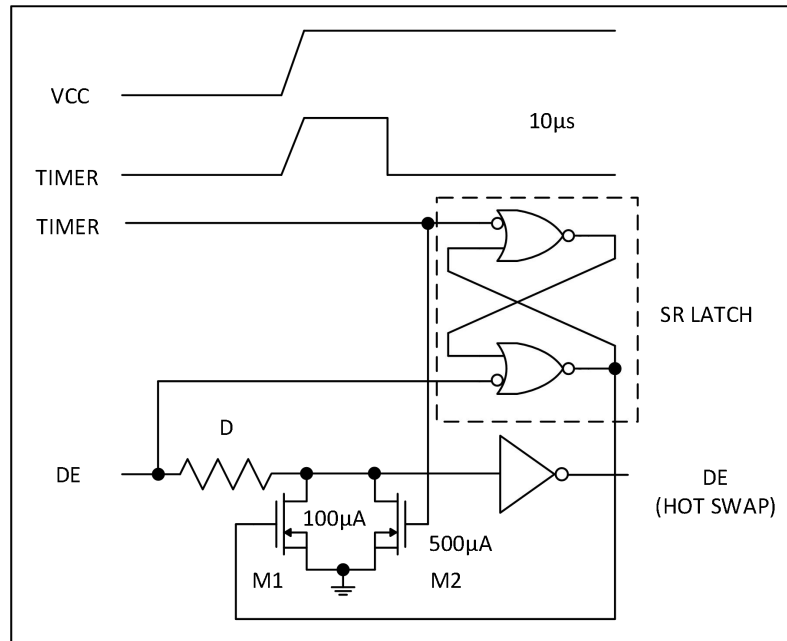

**Figure 9. Simplified Structure of the Driver Enable Pin (DE)**

### ±15kV ESD Protection

The driver output and receiver input of the TK13085 have extra protection against static electricity. The ESD structures withstand high ESD in all states: normal operation, shutdown, and powered down. After an ESD event, the TK13085 keeps working without latchup or damage. ESD protection can be tested in various ways. The transmitter output and receiver input of the TK13085 are characterized for protection to the following limits:

- ±15kV using the Human Body Model
- ±8kV using the Contact Discharge method specified in IEC 61000-4-2
- ±15kV using the Air-Gap Discharge method specified in IEC 61000-4-2

### ESD Test Conditions

ESD performance depends on a variety of conditions.

### Human Body Model

Figure 10a shows the Human Body Model, and Figure 10b shows the current waveform it generates when discharged into a low impedance. This model consists of a 100pF capacitor charged to the ESD voltage of interest, which is then discharged into the test device through a 1.5kΩ resistor.

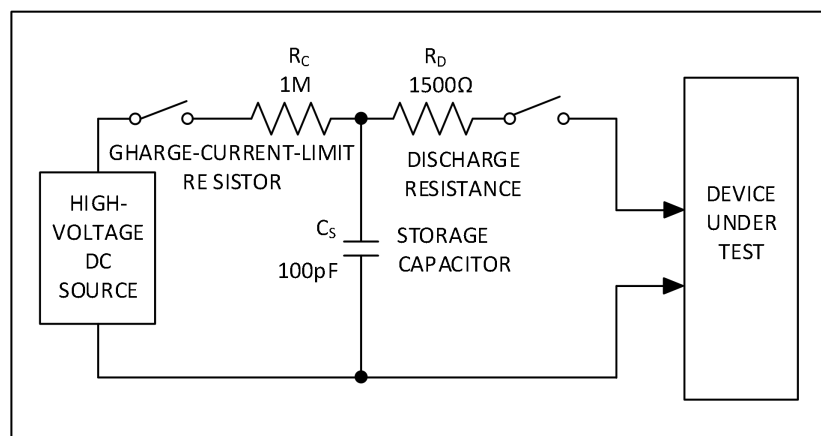

**Figure 10a. Human Body ESD Test Model**

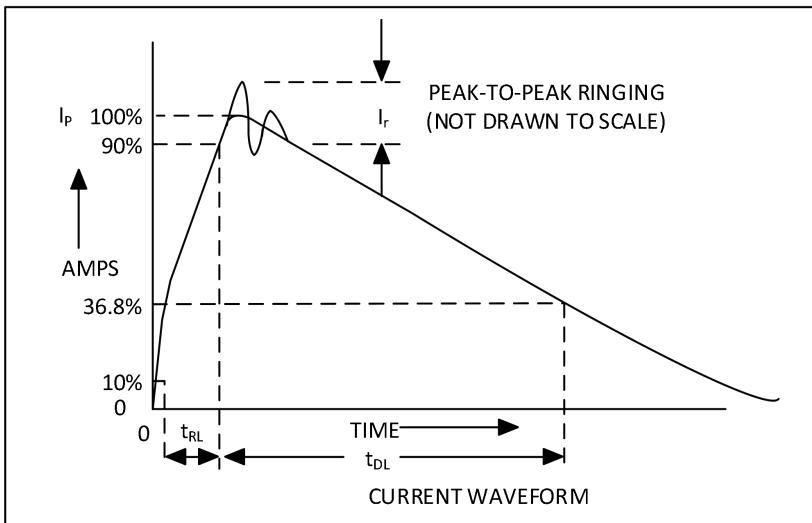

Figure 10b. Human Body Current Waveform

### IEC 61000-4-2

The IEC 61000-4-2 standard covers ESD testing and performance of finished equipment. However, it does not specifically refer to integrated circuits. The TK13085 helps you design equipment to meet IEC 61000-4-2, without the need for additional ESD-protection components. The major difference between tests done using the Human Body Model and IEC 61000-4-2 is higher peak current in IEC 61000-4-2 because series resistance is lower in the IEC 61000-4-2 model. Hence, the ESD withstand voltage measured to IEC 61000-4-2 is generally lower than that measured using the Human Body Model. [Figure 10c](#) shows the IEC 61000-4-2 model, and [Figure 10d](#) shows the current waveform for IEC 61000-4-2 ESD Contact Discharge test.

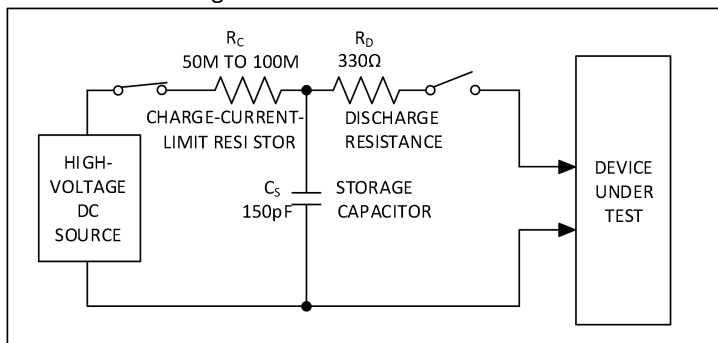

Figure 10c. IEC 61000-4-2 ESD Test Model

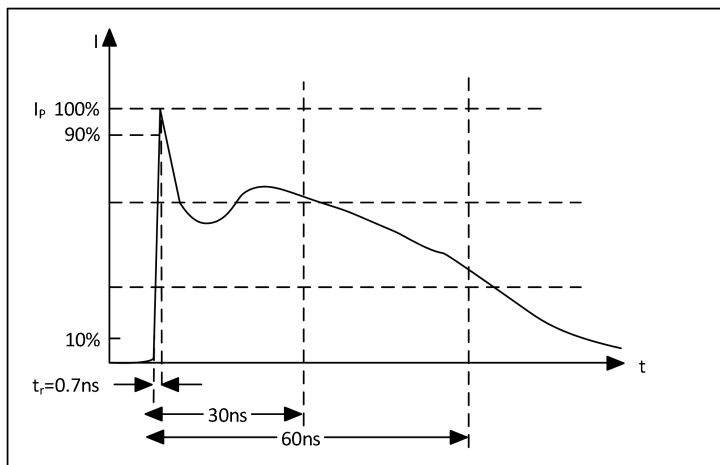

Figure 10d. IEC 61000-4-2 ESD Generator Current Waveform

## Machine Model

The machine model for ESD tests all pins using a 200pF storage capacitor and zero discharge resistance. The objective is to emulate the stress caused when I/O pins are contacted by handling equipment during test and assembly. Of course, all pins require this protection, not just RS-485 inputs and outputs.

## APPLICATIONS INFORMATION

The standard RS-485 receiver input impedance is 12k $\Omega$  (1-unit load), and the standard driver can drive up to 32-unit loads. The TK13085 has a 1/8-unit load receiver input impedance (96k $\Omega$ ), allowing up to 256 transceivers to be connected in parallel on one communication line. Any combination of the TK13085, as well as other RS-485 transceivers with a total of 32-unit loads or fewer, can be connected to the line.

## Reduced EMI and Reflections

The TK13085 features reduced slew-rate drivers that minimize EMI and reduce reflections caused by improperly terminated cables, allowing error-free data transmission up to 1Mbps.

## Low-Power Shutdown Mode

Low-power shutdown mode is initiated by bringing both RE high and DE low. In shutdown, the devices typically draw only 2.0 $\mu$ A of supply current. RE and DE can be driven simultaneously; the devices are guaranteed not to enter shutdown if  $\overline{\text{RE}}$  is high and DE is low for less than 50ns. If the inputs are in this state for at least 700ns, the devices are guaranteed to enter shutdown. Enable times  $t_{ZH}$  and  $t_{ZL}$  (see the Switching Characteristics section) assume the devices were not in a low-power shutdown state. Enable times  $t_{ZH(SHDN)}$  and  $t_{ZL(SHDN)}$  assume the devices were in shutdown state. It takes drivers and receivers longer to become enabled from low-power shutdown mode ( $t_{ZH(SHDN)}$ ,  $t_{ZL(SHDN)}$ ) than from driver/receiver-disable mode ( $t_{ZH}$ ,  $t_{ZL}$ ).

## Driver Output Protection

Two mechanisms prevent excessive output current and power dissipation caused by faults or by bus contention. The first, a foldback current limit on the output stage, provides immediate protection against short circuits over the whole common-mode voltage range (see the Typical Operating Characteristics). The second, a thermal-shutdown circuit, forces the driver outputs into a high-impedance state if the die temperature exceeds +175 $^{\circ}$ C (typ).

## Line Length

The RS-485/RS-422 standard covers line lengths up to 4000ft. For line lengths greater than 4000ft, it may be necessary to implement a line repeater.

## TYPICAL APPLICATIONS

The TK13085 transceiver is designed for bidirectional data communications on multipoint bus transmission lines. Figure 11 shows a typical network applications circuit. To minimize reflections, terminate the line at both ends in its characteristic impedance, and keep stub lengths off the main line as short as possible. The slew-rate-limited TK13085 is more tolerant of imperfect termination.

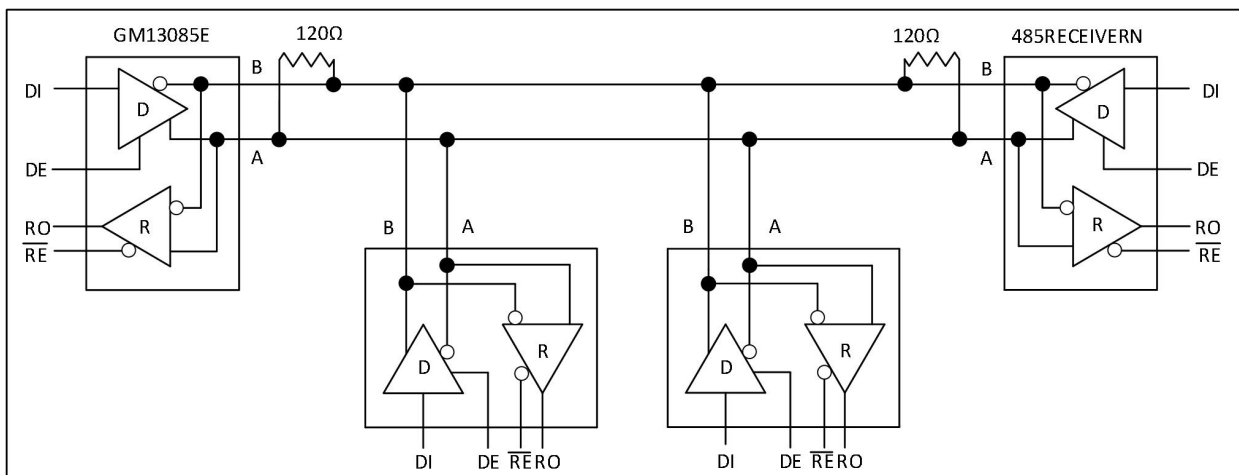
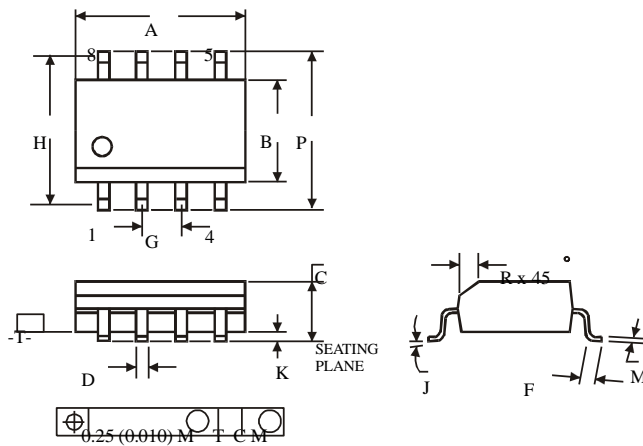

Figure 11. Typical Half-Duplex RS-485 Network

**■ Package Dimensions**
**SOIC8**

Symbol	Dimension, mm	
	MIN	MAX
<b>A</b>	4.8	5
<b>B</b>	3.8	4
<b>C</b>	1.35	1.75
<b>D</b>	0.33	0.51
<b>F</b>	0.4	1.27
<b>G</b>	1.27	
<b>H</b>	5.72	
<b>J</b>	0°	8°
<b>K</b>	0.1	0.25
<b>M</b>	0.19	0.25
<b>P</b>	5.8	6.2
<b>R</b>	0.25	0.5

**NOTES:**

1. Dimensions A and B do not include mold flash or protrusion.
2. Maximum mold flash or protrusion 0.15 mm (0.006) per side for A; for B - 0.25 mm (0.010) per side.