

LOW NOISE QUAD J-FET OPERATIONAL AMPLIFIER

■ Description

The TTESEMI TL074 is a high speed J-FET input quad operational amplifier. It incorporates well matched, high voltage J-FET and bipolar transistors in a monolithic integrated circuit. The device features high slew rates, low input bias and offset current and low offset voltage temperature coefficient.

■ Features

- * Low input bias and offset current
- * Wide common-mode (up to V_{CC}^+) and differential voltage range
- * Output short-circuit protection
- * High input impedance J-FET input stage
- * Internal frequency compensation
- * Latch up free operation
- * Low input bias and offset current
- * Low noise $e_n = 15nV/\sqrt{Hz}$ (typ.)

■ Applications

- Solar energy: string and central inverter
- Motor drives: AC and servo drive control and power stage modules
- Single phase online UPS
- Three phase UPS
- Battery test equipment
- Pro audio mixers

■ Typical Application

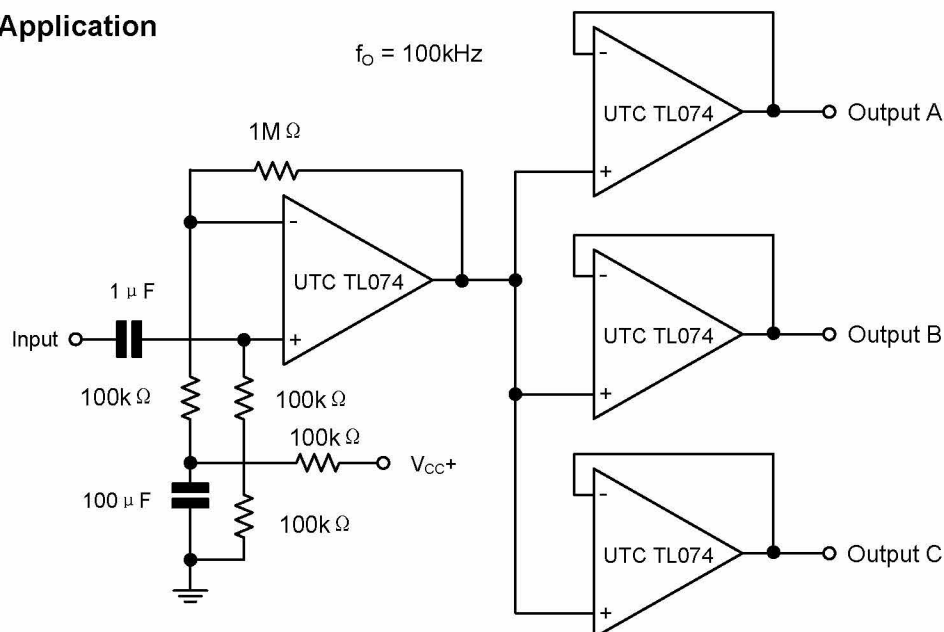

Ordering Information

Part Number	Package	Packing	Temperature(TA)	Package Qty	Remark
TLC074CDR	SOIC-8	Reel	0°C~70°C	2500	
TLC074IDR	SOIC-8	Reel	-40°C~85°C	2500	

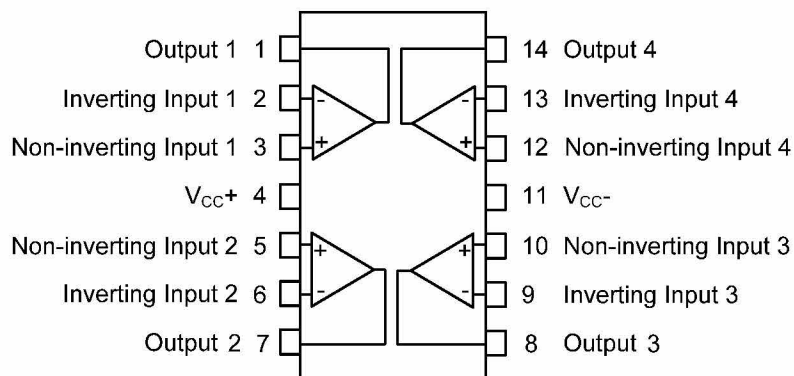
Pin Assignment

Pin Description

NAME	PIN	I/O	DESCRIPTION
1IN+	3	I	Non-inverting input, Channel 1
1IN-	2	I	Inverting input, Channel 1
1OUT	1	O	Output, Channel 1
2IN+	5	I	Non-inverting input, Channel 2
2IN-	6	I	Inverting input, Channel 2
2OUT	7	O	Output, Channel 2
V _{CC+}	4	—	Positive (highest) supply
V _{CC-}	11	—	Negative (lowest) supply
3IN+	10	I	Non-inverting input, Channel 3
3IN-	9	I	Inverting input, Channel 3
3OUT	8	O	Output, Channel 3
4IN+	12	I	Non-inverting input, Channel 4
4IN-	13	I	Inverting input, Channel 4
4OUT	14	O	Output, Channel 4

■ ABSOLUTE MAXIMUM RATINGS

(TA=25°C, unless otherwise specified)

PARAMETER		SYMBOL	RATINGS	UNIT
Supply Voltage (Note 2)		V _{CC}	±18	V
Input Voltage (Note 3)		V _{IN}	±15	V
Differential Input Voltage (Note 4)		V _{ID}	±30	V
Power Dissipation	SOP-14	P _D	600	mW
Output Short-Circuit Duration (Note 5)			Infinite	
Operating Temperature		T _{OPR}	-40 ~ +125 (Note 6)	°C
Storage Temperature Range		T _{STG}	-65 ~ +150	°C

- Notes: 1. Absolute maximum ratings are those values beyond which the device could be permanently damaged. Absolute maximum ratings are stress ratings only and functional device operation is not implied.
2. All voltage values, except differential voltage, are with respect to the zero reference level (ground) of the supply voltages where the zero reference level is the midpoint between V_{CC-} and V_{CC+}.
3. The magnitude of the input voltage must never exceed the magnitude of the supply voltage or 15 volts, whichever is less.
4. Differential voltages are at the non-inverting input terminal with respect to the inverting input terminal.
5. The output may be shorted to ground or to either supply. Temperature and/or supply voltages must be limited to ensure that the dissipation rating is not exceeded.
6. It is guarantee by design, not 100% be tested.

■ THERMAL DATA

PARAMETER		SYMBOL	RATINGS	UNIT
Junction to Ambient	SOP-14	θ _{JA}	250	°C/W
Junction to Case	SOP-14	θ _{JC}	80	°C/W

■ Electrical Characteristics

(VCC=±15V, TA=25 °C, unless otherwise specified)

PARAMETER	SYMBOL	TEST CONDITIONS	MIN	TYP	MAX	UNIT
Input Offset Voltage (RS=50Ω)	IO	TA=25°C		3	10	mV
		TMIN ≤ TA ≤ TMAX			7	
Input Offset Voltage Drift	DVIO			10		μV/°C
Input Offset Current (Note)	IIO	TA=25°C		5	100	pA
		TMIN ≤ TA ≤ TMAX			4	nA
Input Bias Current (Note)	IIB	TA=25°C		20	200	pA
		TMIN ≤ TA ≤ TMAX			20	nA
Input Common Mode Voltage Range	VICM		±11	-12~+15		V
Output Voltage Swing	VO(SW)	TA=25°C, RL=2kΩ,	±1	±12		V
		TA=25°C, RL=10kΩ	±12	±13.5		V
		TMIN ≤ TA ≤ TMAX, RL=2kΩ	±10			V
		TMIN ≤ TA ≤ TMAX, RL=10kΩ	±12			V
Large Signal Voltage Gain (RL=2kΩ, VOUT=±10V)	Avd	TA=25°C		200		V/mV
		TMIN ≤ TA ≤ TMAX	15			
Gain Bandwidth Product (TA=25°C)	GBP	VIN=10mV, RL=2kΩ, CL=100pF, f=100kHz	2.5	4		MHz
Input Resistance	RI			10 ¹²		Ω
Common Mode Rejection Ratio (RS=50Ω)	CMR	TA=25°C		86		dB
		TMIN ≤ TA ≤ TMAX	70			
Supply Voltage Rejection Ratio (RS=50Ω)	SVR	TA=25°C		86		dB
		TMIN ≤ TA ≤ TMAX	70			
Supply Current, No Load	ICC	TA=25°C		1.4	2.5	mA
Channel Separation (AV=100, TA=25°C)	V01/V02			120		dB
Output Short-Circuit Current	IOS	TA=25°C	10	40	60	mA
		TMIN ≤ TA ≤ TMAX	10		60	mA
Slew Rate (TA=25°C)	SR	VIN=10V, RL=2kΩ CL=100pF, unity gain	6	10		V/μs
Rise Time (TA=25°C)	tr	VIN=20mV, RL=2kΩ CL=100pF, unity gain		0.1		μs
Overshoot (TA=25°C)	KOV	VIN=20mV, RL=2kΩ CL=100pF, unity gain		10		%
Total Harmonic Distortion (TA=25°C)	THD	AV=20dB, f=1kHz, RL=2kΩ, CL=100pF, VOUT=2Vpp)		0.01		%
Phase Margin	Φm			45		Degree s
Equivalent Input Noise Voltage (RS=100Ω, f=1KHz)	eN			15		$\frac{nV}{\sqrt{Hz}}$

Note: The Input bias currents are junction leakage currents, which approximately double for every 10°C increase in the junction temperature.

■ PARAMETER MEASUREMENT INFORMATION

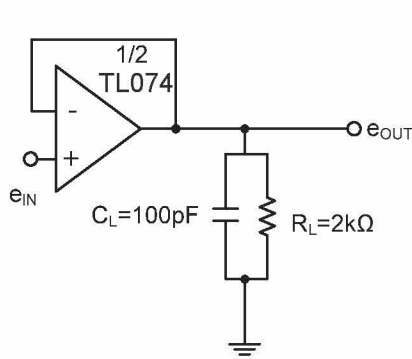

Fig2. Voltage Follower

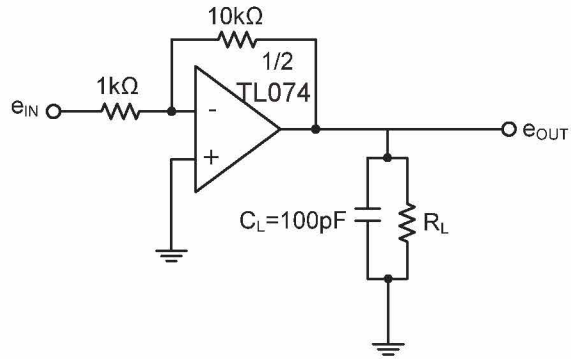

Fig3. Gain-of-10 Inverting Amplifier

■ Functional Block Diagram

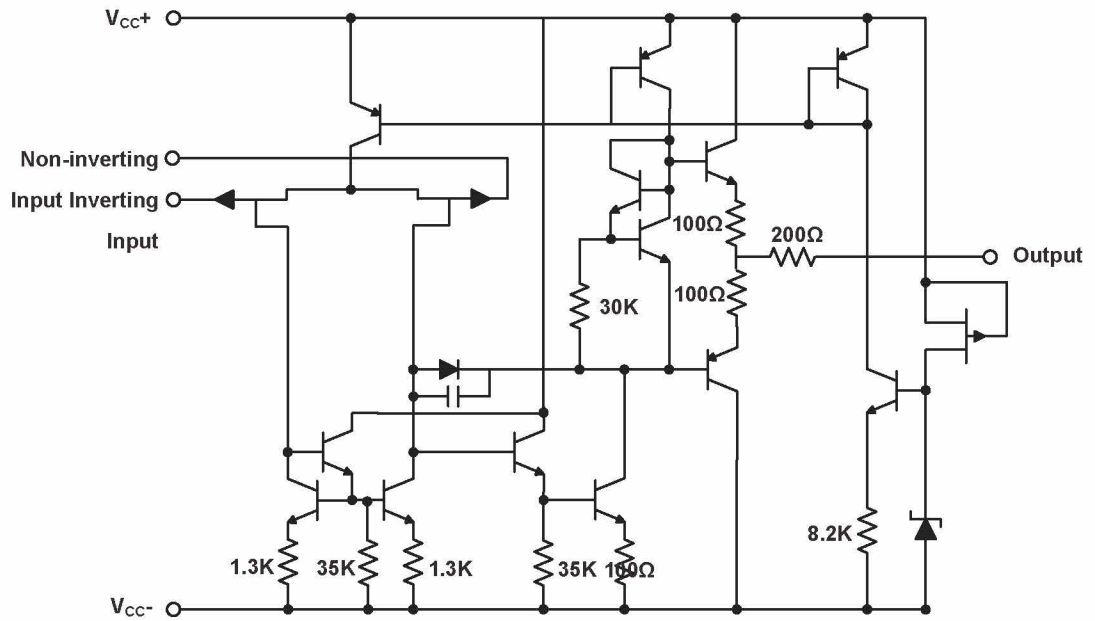
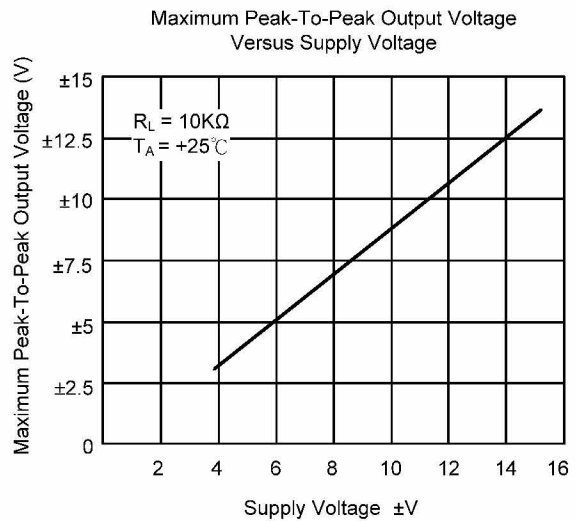
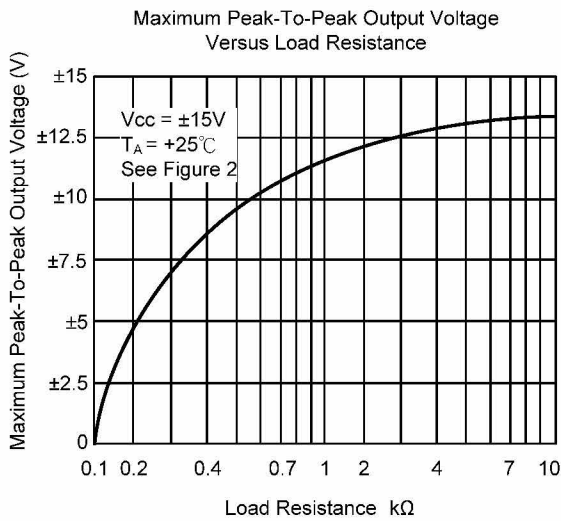
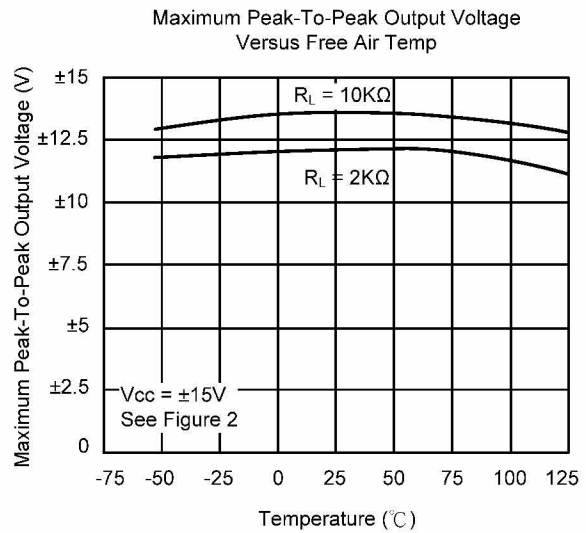
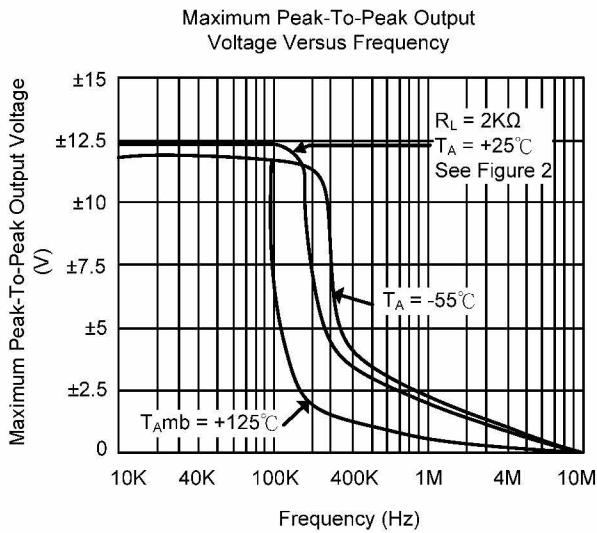
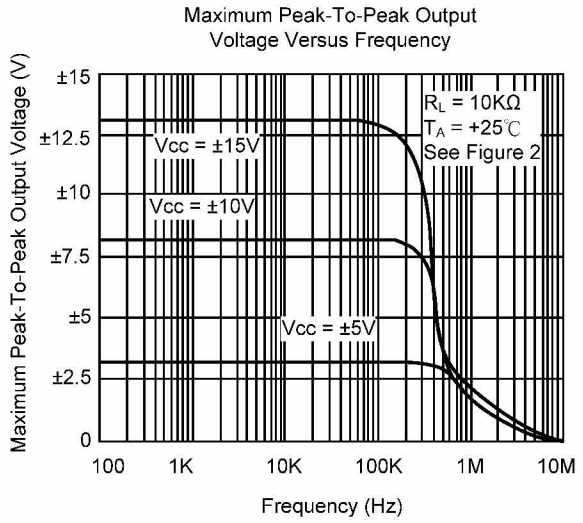
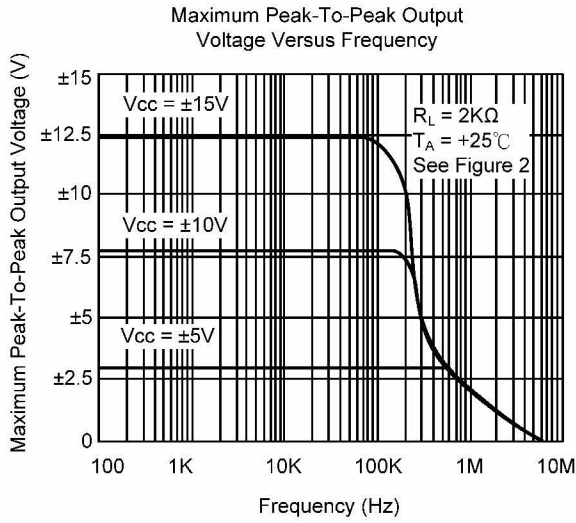
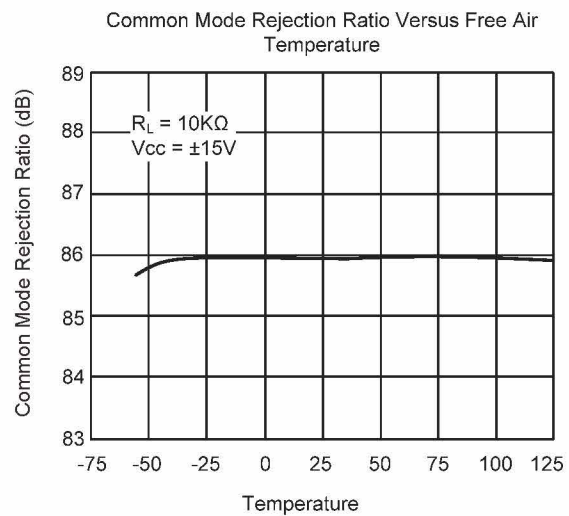
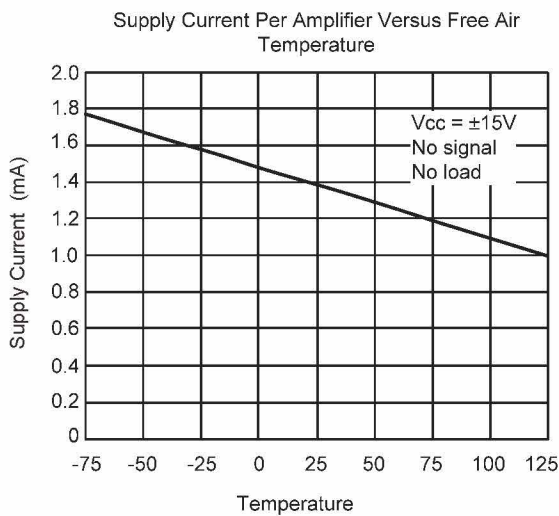
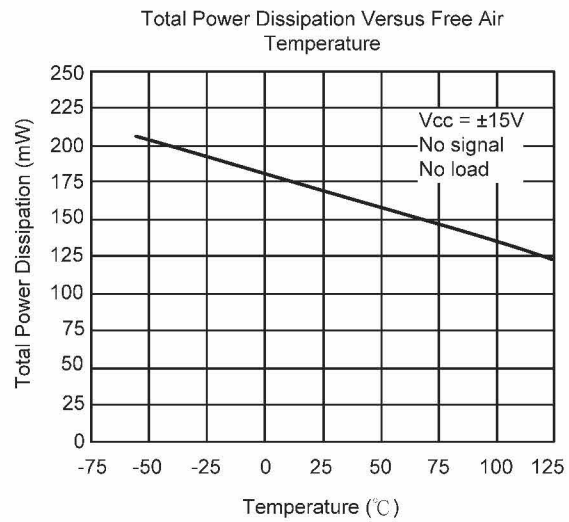
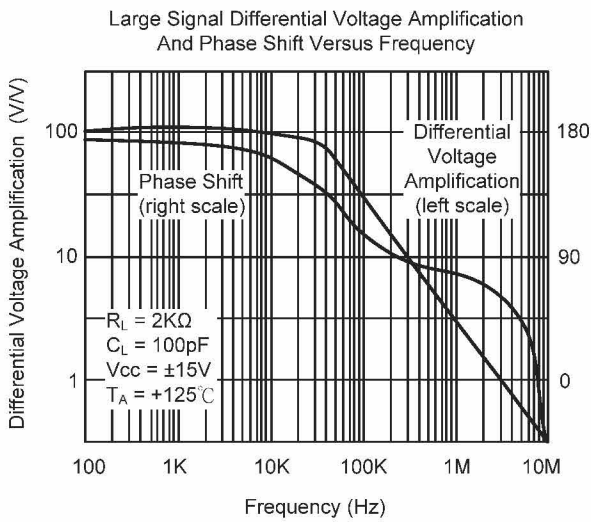
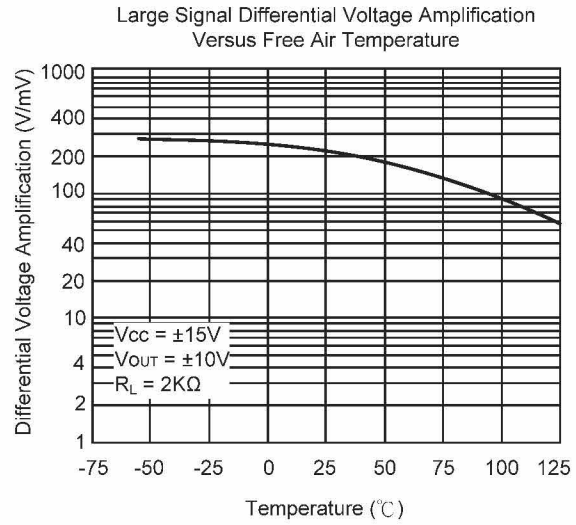
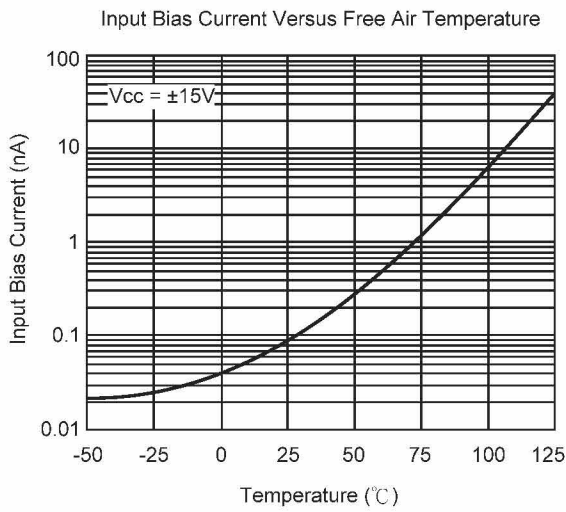
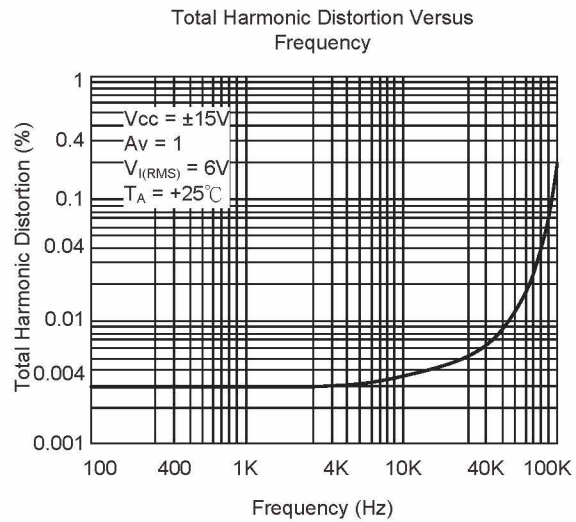
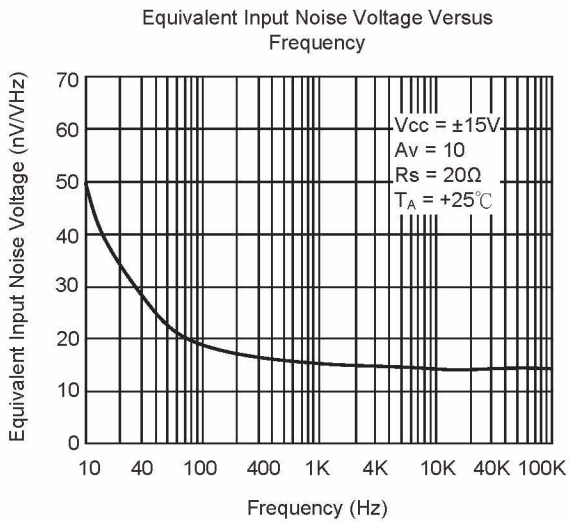
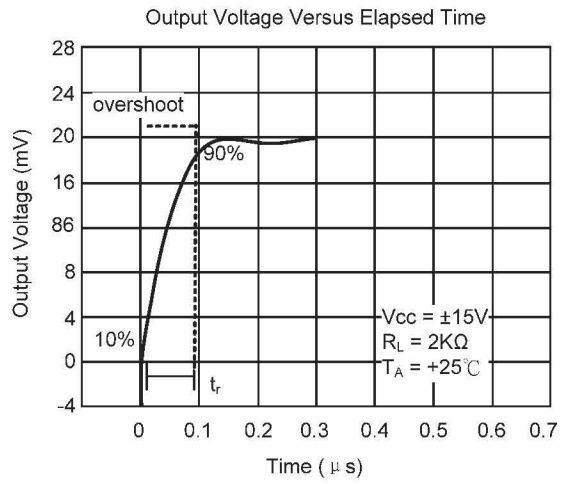
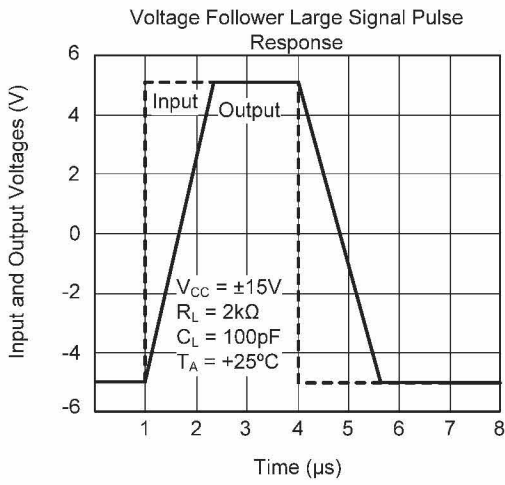

Fig4. Functional Block Diagram

■ TYPICAL CHARACTERISTICS

■ **TYPICAL CHARACTERISTICS (Cont.)**



■ TYPICAL CHARACTERISTICS (Cont.)

Package diagram

SOIC14: plastic small outline package; 14 leads; body width 3.9 mm

