

GENERAL PURPOSE DUAL J-FET OPERATIONAL AMPLIFIER

■ Description

The TTESEMI TK9203 is a high speed J-FET input dual operational amplifier. It incorporates well matched, high voltage J-FET and bipolar transistors in a monolithic integrated circuit. The device features high slew rates, low input bias and offset current, and low offset voltage temperature coefficient.

■ Features

- * Low input bias and offset current
- * Wide common-mode (up to V_{CC}^+) and differential voltage range
- * Output short-circuit protect on
- * High input impedance J-FET input stage
- * Internal frequency compensation
- * Latch up free operation
- * High slewrate: $26V/\mu s$

■ Applications

- White Goods (Refrigerators, Washing Machines)
- Hand-held Monitoring Systems
- Configuration Control and Print Support
- Transducer Interfaces
- Battery-Powered Applications

■ Functional Block Diagram

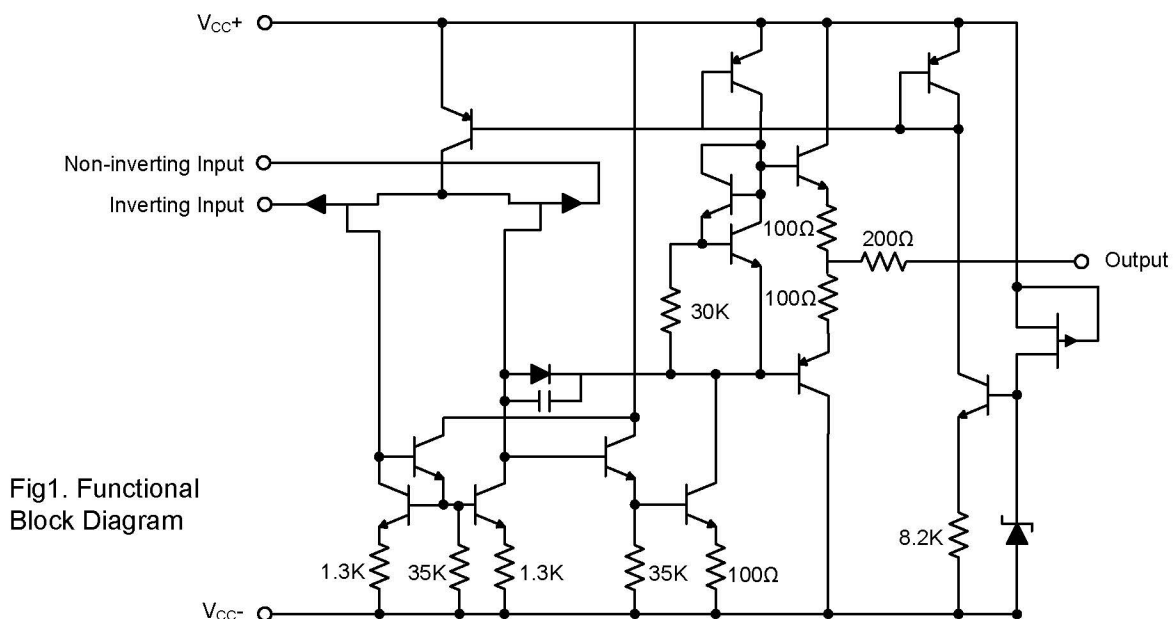

Fig1. Functional Block Diagram

■ Ordering Information

Part Number	Package	Packing	Temperature(TA)	Package Qty	Remark
TK9203IA	SOIC-8	Reel	-40°C~+85°C	2500	

■ Pin Assignment

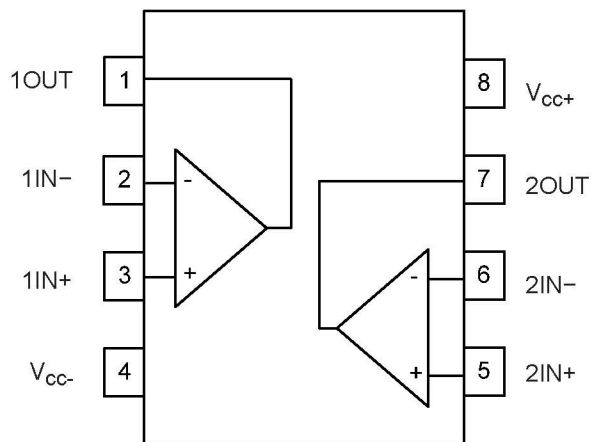

Fig2. SOIC-8 Package

■ Pin Description

NAME	PIN	I/O	DESCRIPTION
1IN+	3	I	Non-inverting input, Channel 1
1IN-	2	I	Inverting input, Channel 1
1OUT	1	O	Output, Channel 1
2IN+	5	I	Non-inverting input, Channel 2
2IN-	6	I	Inverting input, Channel 2
2OUT	7	O	Output, Channel 2
V _{cc+}	8	—	Positive (highest) supply
V _{cc-}	4	—	Negative (lowest) supply

■ ABSOLUTE MAXIMUM RATINGS

(TA=25°C, unless otherwise specified)

PARAMETER		SYMBOL	RATINGS	UNIT
Supply Voltage (Note 2)		V_{CC}	± 18	V
Input Voltage (Note 3)		V_{IN}	± 15	V
Differential Input Voltage (Note 4)		V_{ID}	± 30	V
Power Dissipation	SOP-8	P_D	440	mW
Output Short-Circuit Duration (Note 5)			Infinite	
Operating Temperature		T_{OPR}	-40 ~ +125 (Note 6)	°C
Storage Temperature Range		T_{STG}	-65 ~ +150	°C

- Notes: 1. Absolute maximum ratings are those values beyond which the device could be permanently damaged. Absolute maximum ratings are stress ratings only and functional device operation is not implied.
2. All voltage values, except differential voltage, are with respect to the zero reference level (ground) of the supply voltages where the zero reference level is the midpoint between V_{CC-} and V_{CC+} .
3. The magnitude of the input voltage must never exceed the magnitude of the supply voltage or 15 volts, whichever is less.
4. Differential voltages are at the non-inverting input terminal with respect to the inverting input terminal.
5. The output may be shorted to ground or to either supply. Temperature and/or supply voltages must be limited to ensure that the dissipation rating is not exceeded.
6. It is guarantee by design, not 100% be tested.

■ THERMAL DATA

PARAMETER		SYMBOL	RATINGS	UNIT
Junction to Ambient	SOP-8	θ_{JA}	125	°C/W
Junction to Case	SOP-8	θ_{JC}	40	°C/W

■ Electrical Characteristics $V_{DD} = 5V$

(VCC=±15V, TA=25 °C, unless otherwise specified)

PARAMETER	SYMBOL	TEST CONDITIONS	MIN	TYP	MAX	UNIT
Input Offset Voltage ($R_S=50\Omega$)	I_{IO}	$T_A=25^\circ C$		3	10	mV
		$T_{MIN} \leq T_A \leq T_{MAX}$			13	
Input Offset Voltage Drift	D_{VIO}			10		$\mu V/^\circ C$
Input Offset Current (Note)	I_{IO}	$T_A=25^\circ C$		5	100	pA
		$T_{MIN} \leq T_A \leq T_{MAX}$			10	nA
Input Bias Current (Note)	I_{IB}	$T_A=25^\circ C$		20	400	pA
		$T_{MIN} \leq T_A \leq T_{MAX}$			20	nA
Input Common Mode Voltage Range	V_{ICM}		±11	-12~+15		V
Output Voltage Swing	$V_{O(SW)}$	$T_A=25^\circ C, R_L=2k\Omega,$	±1	±12		V
		$T_A=25^\circ C, R_L=10k\Omega$	±12	±13.5		V
		$T_{MIN} \leq T_A \leq T_{MAX}, R_L=2k\Omega$	±10			V
		$T_{MIN} \leq T_A \leq T_{MAX}, R_L=10k\Omega$	±12			V
Large Signal Voltage Gain ($R_L=2k\Omega, V_{OUT}=\pm 10V$)	A_{vd}	$T_A=25^\circ C$		200		V/mV
		$T_{MIN} \leq T_A \leq T_{MAX}$	15			
Gain Bandwidth Product ($T_A=25^\circ C$)	GBP	$V_{IN}=10mV, R_L=2k\Omega,$ $C_L=100pF, f=100kHz$		4	10	MHz
Input Resistance	R_i			10^{12}		Ω
Common Mode Rejection Ratio ($R_S=50\Omega$)	CMR	$T_A=25^\circ C$		86		dB
		$T_{MIN} \leq T_A \leq T_{MAX}$	70			
Supply Voltage Rejection Ratio ($R_S=50\Omega$)	SVR	$T_A=25^\circ C$		86		dB
		$T_{MIN} \leq T_A \leq T_{MAX}$	70			
Supply Current, No Load	I_{CC}	$T_A=25^\circ C$		2.3	5.6	mA
Channel Separation ($A_v=100, T_A=25^\circ C$)	V_{O1}/V_{O2}			120		dB
Output Short-Circuit Current	I_{OS}	$T_A=25^\circ C$	10	40	60	mA
		$T_{MIN} \leq T_A \leq T_{MAX}$	10		60	mA
Slew Rate ($T_A=25^\circ C$)	SR	$V_{IN}=10V, R_L=2k\Omega$ $C_L=100pF, \text{unity gain}$		13	26	V/ μs
Rise Time ($T_A=25^\circ C$)	t_R	$V_{IN}=20mV, R_L=2k\Omega$ $C_L=100pF, \text{unity gain}$		0.1		μs
Overshoot ($T_A=25^\circ C$)	K_{OV}	$V_{IN}=20mV, R_L=2k\Omega$ $C_L=100pF, \text{unity gain}$		10		%
Total Harmonic Distortion ($T_A=25^\circ C$)	THD	$A_v=20dB, f=1kHz, R_L=2k\Omega,$ $C_L=100pF, V_{OUT}=2V_{pp}$)		0.01		%
Phase Margin	Φ_m			45		Degree s
Equivalent Input Noise Voltage ($R_S=100\Omega, f=1kHz$)	eN			15		$\frac{nV}{\sqrt{Hz}}$

Note: The Input bias currents are junction leakage currents, which approximately double for every 10°C increase in the junction temperature.

■ **PARAMETER MEASUREMENT INFORMATION**

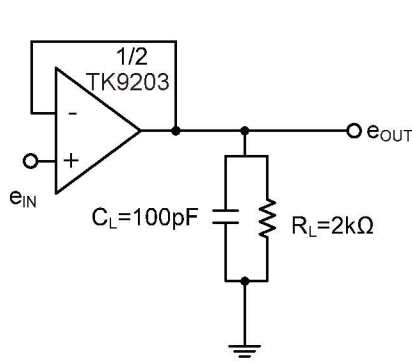

Figure 1. Voltage Follower

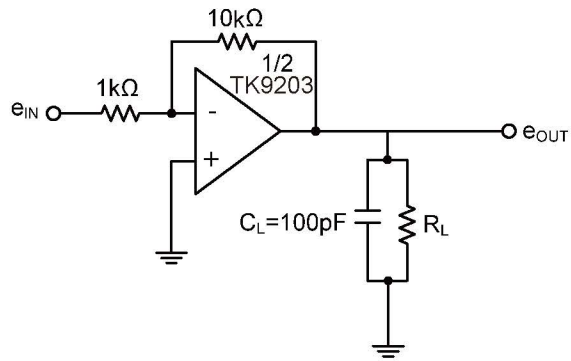
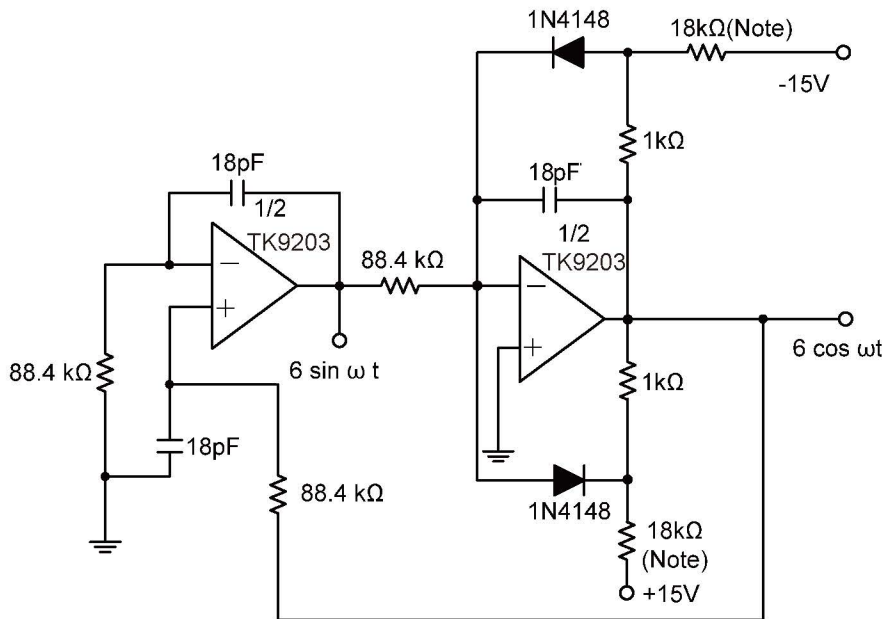

Figure 2. Gain-of-10 Inverting Amplifier

■ **TYPICAL APPLICATION CIRCUIT**

100 KHz Quadruple Oscillators

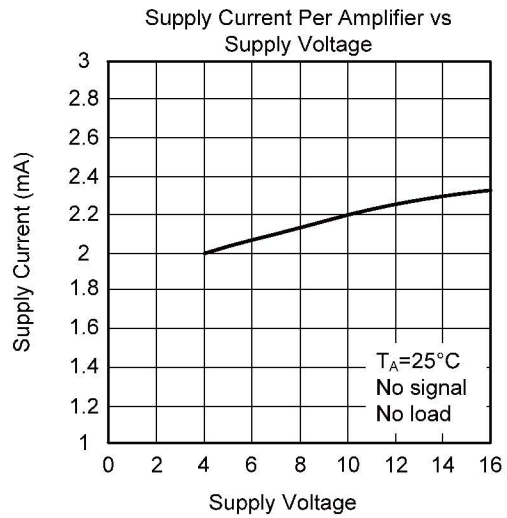
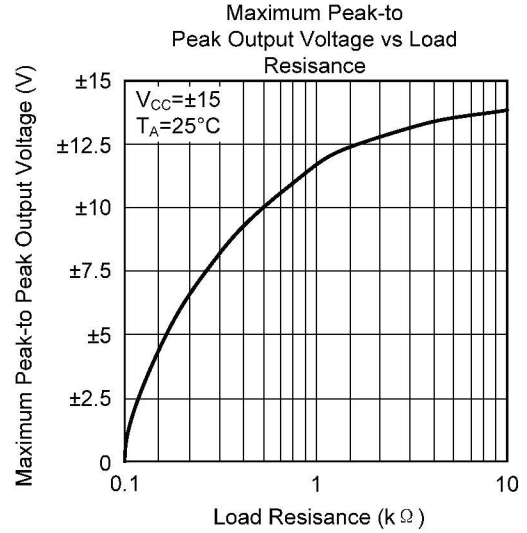
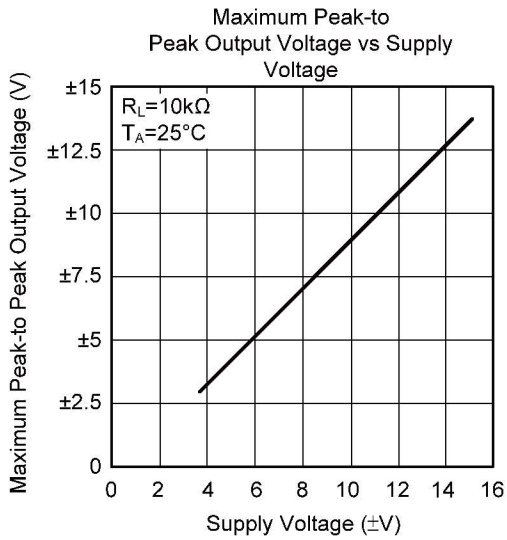
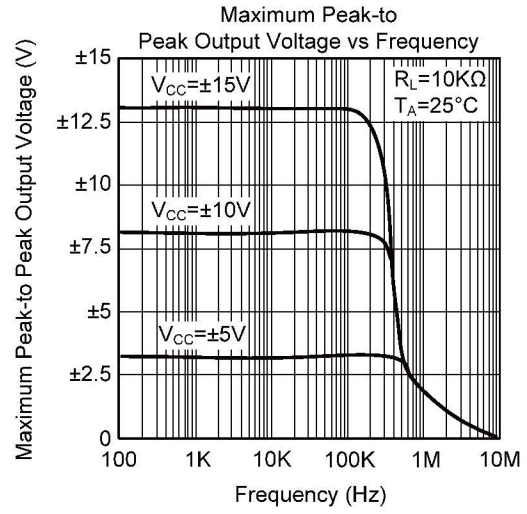
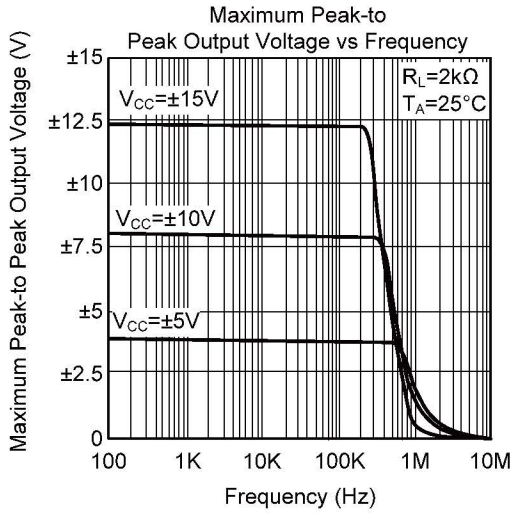

Note: These resistors values may be adjusted for a symmetrical output

■ TYPICAL CHARACTERISTICS

PACKAGE OUTLINE SOIC - 8, 1.75 mm max height

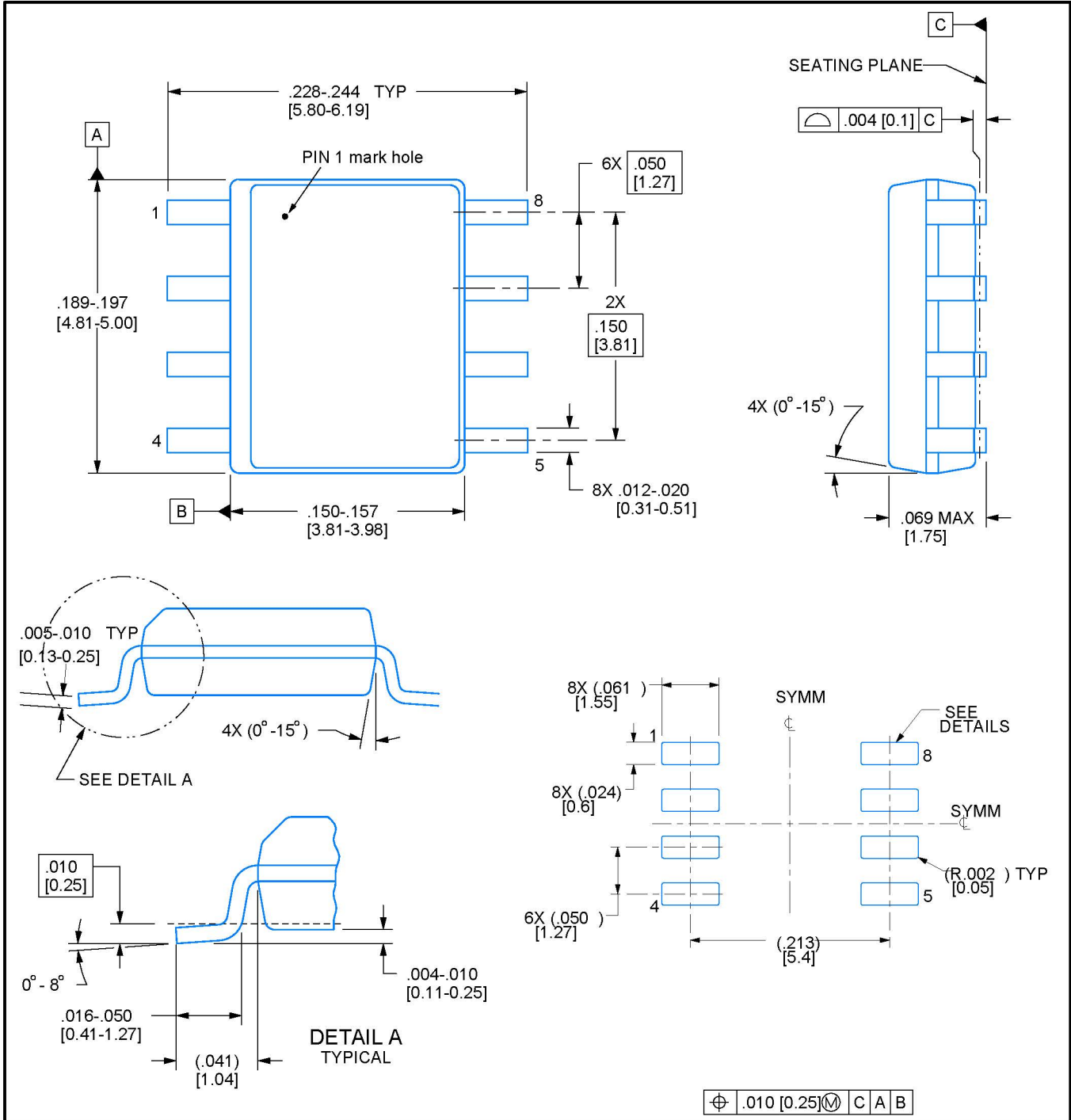

NOTES: Linear dimensions are in inches [millimeters]. This dimension does not include mold flash, protrusions, or gate burrs. Mold flash, protrusions, or gate burrs shall not exceed .006 [0.15] per side.