

## Low-Power, RS-485/RS-422 Transceivers

### ■ Description

The TK481 is low-power transceivers for RS-485 and RS-422 communication. IC contains one driver and one receiver.

The driver slew rates of the TK481 is not limited, allowing them to transmit up to 2.5Mbps.

These transceivers draw between 120 $\mu$ A and 500 $\mu$ A of supply current when unloaded or fully loaded with disabled drivers. All parts operate from a single 5V supply. Drivers are short-circuit current limited and are protected against excessive power dissipation by thermal shutdown circuitry that places the driver outputs into a high-impedance state.

The receiver input has a fail-safe feature that guarantees a logic-high output if the input is open circuit. The TK481 is designed for half-duplex applications.

### ■ Features

- Low Quiescent Current: 300 $\mu$ A
- -8V to +12.5V Common-Mode Input Voltage Range
- Three-State Outputs
- 40ns Propagation Delays, 5ns Skew
- Half-Duplex Version Available
- Operate from a Single 5V Supply
- Allows up to 32 Transceivers on the Bus
- Data rate: 2.5Mbps
- Current-Limiting and Thermal Shutdown for Driver Overload Protection
- Enhanced ESD Specifications ("EC" and "EE" only):
  - ±15kV IEC61000-4-2 Air Discharge
  - ±8kV IEC61000-4-2 Contact Discharge

### ■ Ordering Information

Part Number	Package	Packing	Temperature(TA)	Package Qty	ESD
TK481CSA	SOIC-8	Reel	0°C ~ 70°C	2500	
TK481ESA	SOIC-8	Reel	-40°C ~ 85°C	2500	
TK481ECSA	SOIC-8	Reel	0°C ~ 70°C	2500	±15KV
TK481EESA	SOIC-8	Reel	-40°C ~ 85°C	2500	±15KV

Note: Please contact us to customize DIP packaging device.

## ■ Pin Assignment

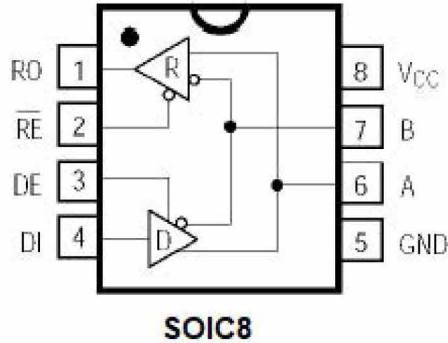

## ■ Pin Description

PIN NO.	PIN NAME	DESCRIPTION
1	RO	Receiver Output. If $A > B$ by 200mV, RO will be high; if $A < B$ by 200mV, RO will be low.
2	$\overline{RE}$	Receiver Output Enable. RO is enabled when $\overline{RE}$ is low; RO is high impedance when $\overline{RE}$ is high.
3	DE	Driver Output Enable. The driver outputs, Y and Z, are enabled by bringing DE high. They are high impedance when DE is low. If the driver outputs are enabled, the parts function as line drivers. While they are high impedance, they function as line receivers if $\overline{RE}$ is low.
4	DI	Driver Input. A low on DI forces output Y low and output Z high. Similarly, a high on DI forces output Y high and output Z low.
5	GND	Ground
6	A	Noninverting Receiver Input and Noninverting Driver Output
7	B	Inverting Receiver Input and Inverting Driver Output
8	Vcc	Positive Supply: $4.75V \leq VCC \leq 5.25V$

**■ ABSOLUTE MAXIMUM RATINGS**

Supply Voltage ( $V_{CC}$ ) 12V	Continuous Power Dissipation ( $T_A = +70^\circ\text{C}$ )
Control Input Voltage -0.5V to ( $V_{CC} + 0.5\text{V}$ )	8-Pin SOIC (derate 9.09mW/ $^\circ\text{C}$ above $+70^\circ\text{C}$ ) 727mW
Driver Input Voltage (DI) -0.5V to ( $V_{CC} + 0.5\text{V}$ )	8-Pin SOIC (derate 5.88mW/ $^\circ\text{C}$ above $+70^\circ\text{C}$ ) 471mW
Driver Output Voltage (A, B) -8V to +12.5V	Operating Temperature Ranges $-40^\circ\text{C}$ to $+105^\circ\text{C}$
Receiver Input Voltage (A, B) -8V to +12.5V	Storage Temperature Range $-65^\circ\text{C}$ to $+160^\circ\text{C}$
Receiver Output Voltage (RO) -0.5V to ( $V_{CC} + 0.5\text{V}$ )	Lead Temperature (soldering, 10sec) $+300^\circ\text{C}$

\* Stresses beyond those listed under "absolute maximum ratings" may cause permanent damage to the device. These are stress ratings only and functional operation of the device at these or any other conditions beyond those indicated under "recommended operating conditions" is not implied. Exposure to absolute-maximum-rated conditions for extended periods may affect device reliability.

**■ DC ELECTRICAL CHARACTERISTICS**

( $V_{CC} = 5\text{V} \pm 5\%$ ,  $T_A = T_{MIN}$  to  $T_{MAX}$ , unless otherwise noted.) (Notes 1, 2)

PARAMETER	SYMBOL	CONDITIONS	MIN	TYP	MAX	UNITS
Differential Driver Output (no load)	$V_{OD1}$				5	V
Differential Driver Output (with load)	$V_{OD2}$	R = 50 $\Omega$ (RS-422)	2			V
		R = 27 $\Omega$ (RS-485), Figure 1	1.5		5	
Change in Magnitude of Driver Differential Output Voltage for Complementary Output States	$\Delta V_{OD}$	R = 27 $\Omega$ or 50 $\Omega$ , Figure 1			0.2	V
Driver Common-Mode Output Voltage	$V_{OC}$	R = 27 $\Omega$ or 50 $\Omega$ , Figure 1			3	V
Change in Magnitude of Driver Common-Mode Output Voltage for Complementary Output States	$\Delta V_{OC}$	R = 27 $\Omega$ or 50 $\Omega$ , Figure 1			0.2	V
Input High Voltage	$V_{IH}$	DE, DI, $\overline{RE}$	2.0			V
Input Low Voltage	$V_{IL}$	DE, DI, $\overline{RE}$			0.8	V
Input Current	$I_{IN1}$	DE, DI, $\overline{RE}$			$\pm 2$	$\mu\text{A}$
Input Current (A, B)	$I_{IN2}$	DE = 0V; $V_{CC} = 0\text{V}$ or 5.25V	$V_{IN} = 12\text{V}$		1.0	mA
			$V_{IN} = -7\text{V}$		-0.8	
Receiver Differential Threshold Voltage	$V_{TH}$	$-7\text{V} \leq V_{CM} \leq 12\text{V}$	-0.2		0.2	V
Receiver Input Hysteresis	$\Delta V_{TH}$	$V_{CM} = 0\text{V}$		70		mV
Receiver Output High Voltage	$V_{OH}$	$I_O = -4\text{mA}$ , $V_{ID} = 200\text{mV}$	3.5			V
Receiver Output Low Voltage	$V_{OL}$	$I_O = 4\text{mA}$ , $V_{ID} = -200\text{mV}$			0.4	V
Three-State (high impedance) Output Current at Receiver	$I_{OZR}$	$0.4\text{V} \leq V_O \leq 2.4\text{V}$			$\pm 1$	$\mu\text{A}$
Receiver Input Resistance	$R_{IN}$	$-7\text{V} \leq V_{CM} \leq 12\text{V}$	12			k $\Omega$

**■ DC ELECTRICAL CHARACTERISTICS (continue)**

 (V<sub>CC</sub> = 5V ±5%, T<sub>A</sub> = T<sub>MIN</sub> to T<sub>MAX</sub>, unless otherwise noted.) (Notes 1, 2)

PARAMETER	SYMBOL	CONDITIONS	MIN	TYP	MAX	UNITS
No-Load Supply Current (Note 3)	I <sub>CC</sub>	DE = V <sub>CC</sub>		500	900	
		$\overline{RE} = 0V$ or V <sub>CC</sub>		300	500	μA
		DE = 0V				
Driver Short-Circuit Current	I <sub>OSD1</sub>	-7V ≤ V <sub>O</sub> ≤ 12V (Note 4)	35		250	mA
VO = High Driver Short-Circuit Current	I <sub>OSD2</sub>	-7V ≤ V <sub>O</sub> ≤ 12V (Note 4)	35		250	mA
VO = Low Receiver Short-Circuit Current	I <sub>OSR</sub>	0V ≤ V <sub>O</sub> ≤ V <sub>CC</sub>	7		95	mA
ESD Protection		A, B, Y and Z pins, tested using Human Body Model		±15		kV

**■ SWITCHING CHARACTERISTICS**

 (V<sub>CC</sub> = 5V ±5%, T<sub>A</sub> = T<sub>MIN</sub> to T<sub>MAX</sub>, unless otherwise noted.) (Notes 1, 2)

PARAMETER	SYMBOL	CONDITIONS	MIN	TYP	MAX	UNITS
Driver Input to Output	t <sub>PLH</sub>	R <sub>DIFF</sub> = 54Ω	10	40	60	ns
	t <sub>PHL</sub>	C <sub>L1</sub> = C <sub>L2</sub> = 100pF	10	40	60	
Driver Output Skew to Output	t <sub>SKEW</sub>	R <sub>DIFF</sub> = 54Ω, C <sub>L1</sub> = C <sub>L2</sub> = 100pF		5	10	ns
Driver Enable to Output High	t <sub>ZH</sub>	C <sub>L</sub> = 100pF, S2 closed		30	60	ns
Driver Enable to Output Low	t <sub>ZL</sub>	C <sub>L</sub> = 100pF, S1 closed		30	60	ns
Driver Disable Time from Low	t <sub>LZ</sub>	C <sub>L</sub> = 15pF, S1 closed		30	60	ns
Driver Disable Time from High	t <sub>HZ</sub>	C <sub>L</sub> = 15pF, S2 closed		30	70	ns
Receiver Input to Output	t <sub>PLH</sub>	R <sub>DIFF</sub> = 54Ω	20	60	100	ns
	t <sub>PHL</sub>	C <sub>L1</sub> = C <sub>L2</sub> = 100pF	20	60	100	
t <sub>PLH</sub> - t <sub>PHL</sub>   Differential Receiver Skew	t <sub>SKD</sub>	R <sub>DIFF</sub> = 54Ω C <sub>L1</sub> = C <sub>L2</sub> = 100pF		13		ns
Receiver Enable to Output Low	t <sub>ZL</sub>	C <sub>RL</sub> = 15pF, S1 closed		30	50	ns
Receiver Enable to Output High	t <sub>ZH</sub>	C <sub>RL</sub> = 15pF, S2 closed		30	50	ns
Receiver Disable Time from Low	t <sub>LZ</sub>	C <sub>RL</sub> = 15pF, S1 closed		30	50	ns
Receiver Disable Time from High	t <sub>HZ</sub>	C <sub>RL</sub> = 15pF, S2 closed		30	50	ns
Maximum Data Rate	f <sub>MAX</sub>		1.5	2.5	5	Mbps

Note 1: All currents into device pins are positive; all currents out of device pins are negative. All voltages are referenced to device ground unless otherwise specified.

 Note 2: All typical specifications are given for V<sub>CC</sub>=5V and T<sub>A</sub>=+25°C.

Note 3: Supply current specification is valid for loaded transmitters when DE=0V.

Note 4: Applies to peak current.

■ TEST CIRCUITS

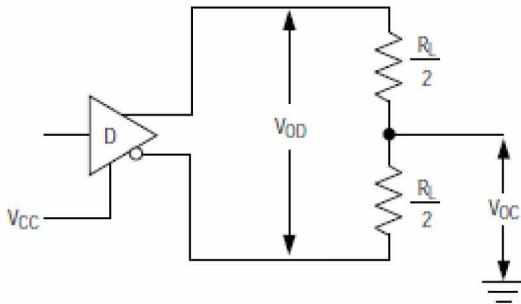

Figure 1. Driver  $V_{OD}$  and  $V_{OC}$

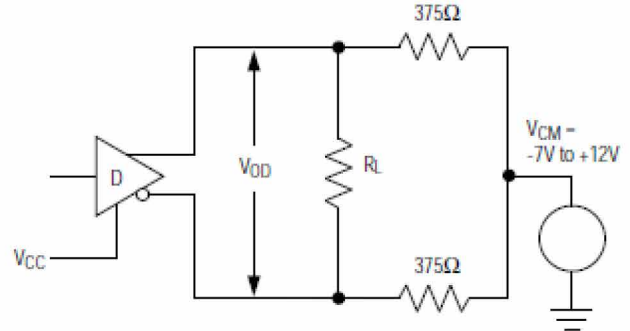

Figure 2. Driver  $V_{OD}$  with Varying Common-Mode Voltage

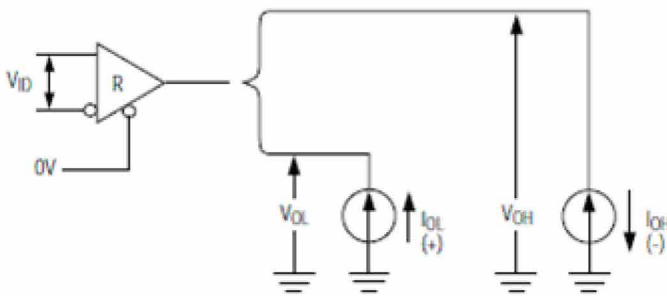

Figure 3. Receiver  $V_{OH}$  and  $V_{OL}$

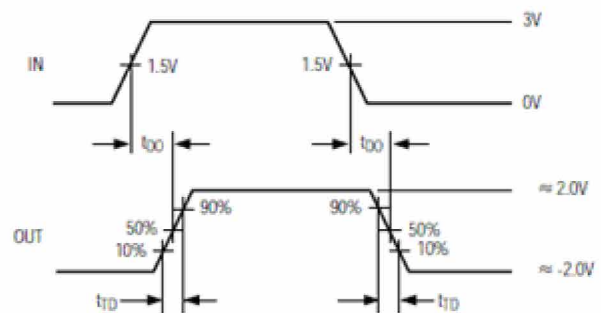
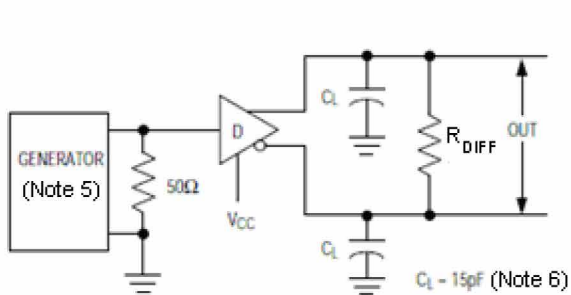

Figure 4. Driver Differential Output Delay and Transition Times

■ TEST CIRCUITS (continue)

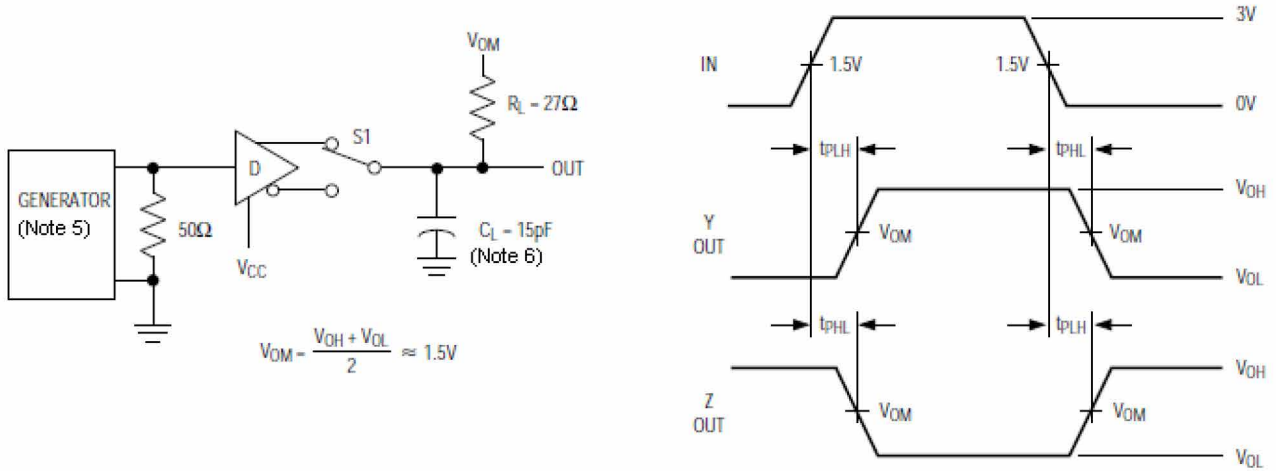

Figure 5. Driver Propagation Times

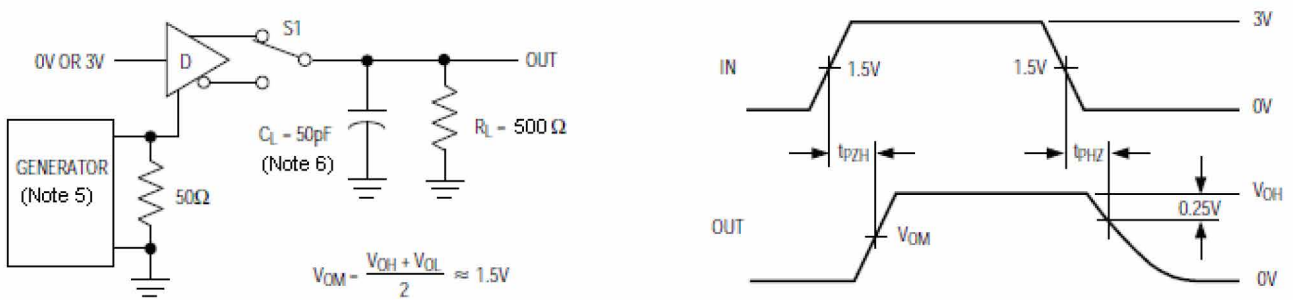

Figure 6. Driver Enable and Disable Times ( $t_{PZH}$ ,  $t_{PSH}$ ,  $t_{PHZ}$ )

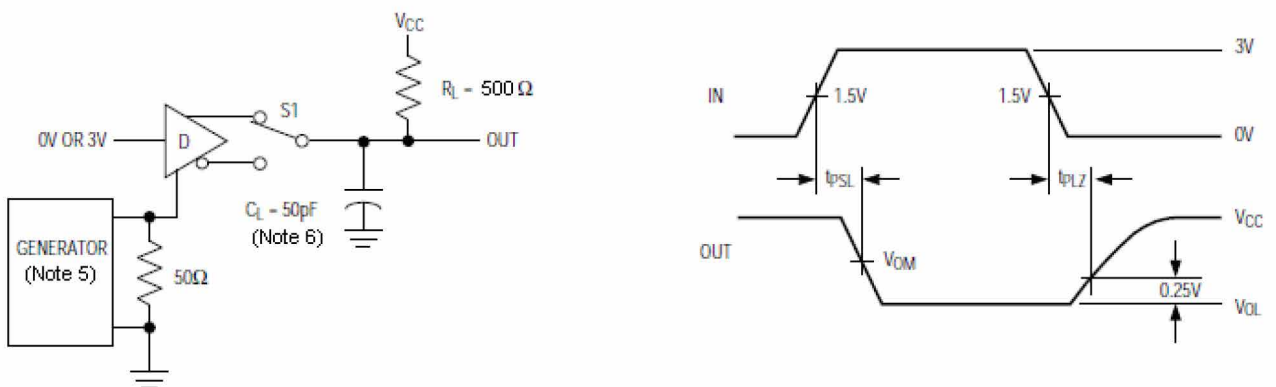

Figure 7. Driver Enable and Disable Times ( $t_{PZL}$ ,  $t_{PSL}$ ,  $t_{PLZ}$ )

■ TEST CIRCUITS (continue)

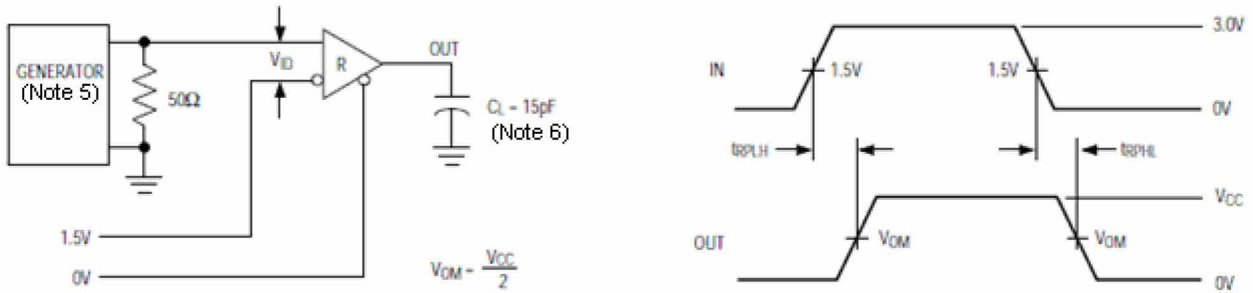

Figure 8. Receiver Propagation Delay

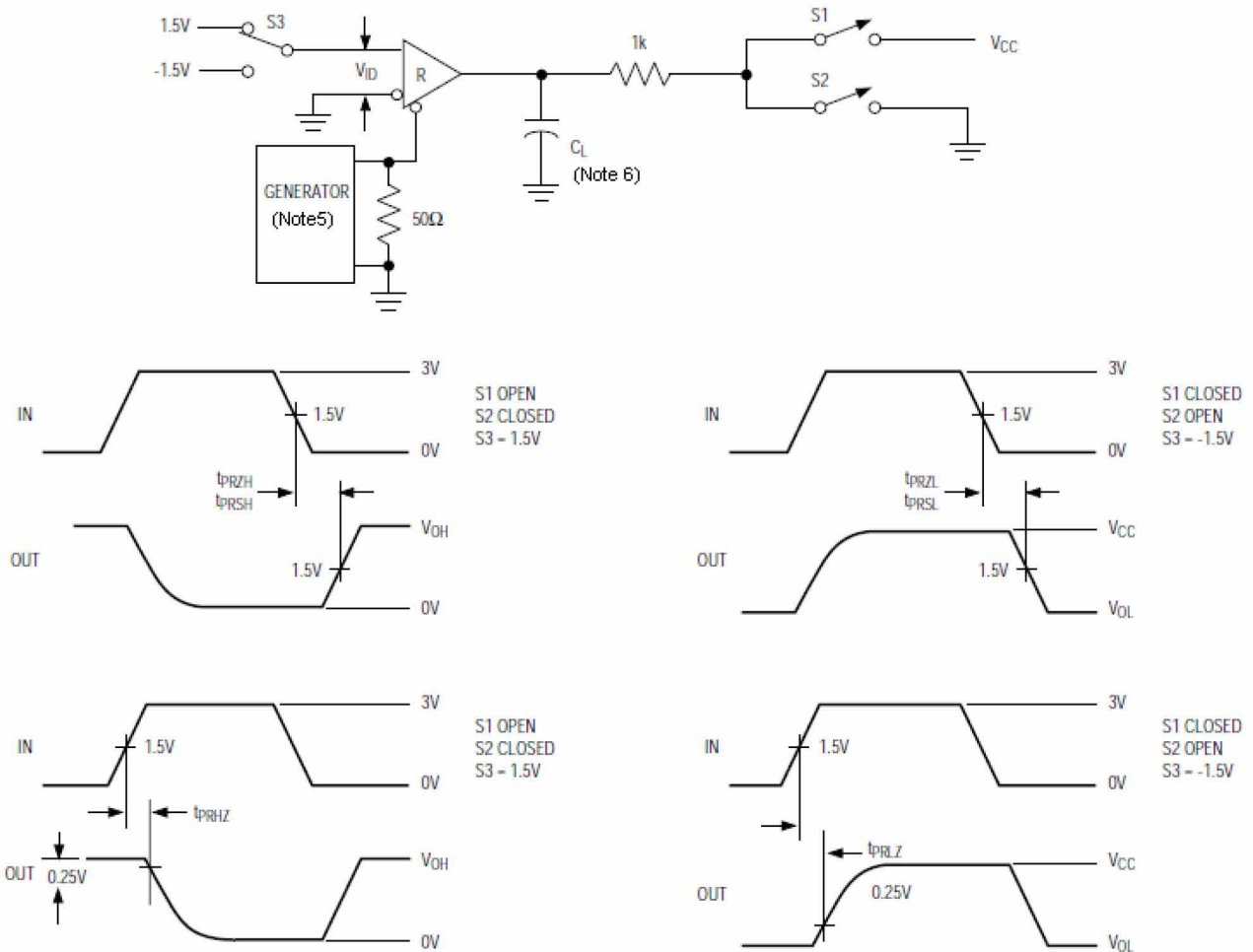

Figure 9. Receiver Enable and Disable Times

**Note 5:** The input pulse is supplied by a generator with the following characteristics: PRR = 250kHz, 50% duty cycle,  $t_r \leq 6.0\text{ns}$ ,  $Z_o = 50\Omega$ .

**Note 6:**  $C_L$  includes probe and stray capacitance.

**Function Tables**

Transmitting				
INPUTS			OUTPUTS X	
RE	DE	DI	Z	Y
X	1	1	0	1
X	1	0	1	0
0	0	X	Z	Z
1	0	X	Z	Z

Receiving			
INPUTS			OUTPUTS
RE	DE	A-B	RO
0	0	+0.2V	1
0	0	-0.2V	0
0	0	open	1
1	0	X	Z

X-don't care

Z-high impedance

**Typical Information**

Figure 10. TK481 Typical RS-485 Network

**Driver Output Protection**

Excessive output current and power dissipation caused by faults or by bus contention are prevented by two mechanisms. A foldback current limit on the output stage provides immediate protection against short circuits over the whole common-mode voltage range. In addition, a thermal shutdown circuit forces the driver outputs into a high-impedance state if the die temperature rises excessively.

**Propagation Delay**

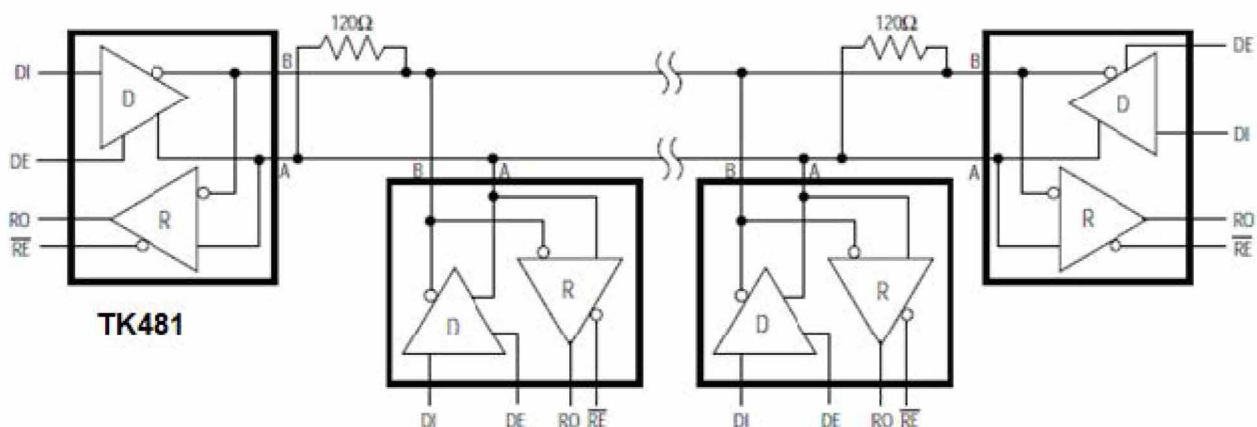
Skew time is simply the difference between the low-to-high and high-to-low propagation delay. Small driver/receiver skew times help maintain a symmetrical mark-space ratio (50% duty cycle).

The receiver skew time,  $|t_{PRHL} - t_{PRHL}|$ , is under 13ns. The driver skew times are 5ns for the TK481.

**Typical Applications**

TK481 transceivers are designed for bidirectional data communications on multipoint bus transmission lines. Figure 10 shows typical network applications circuits. These parts can also be used as line repeaters, with cable lengths longer than 4000 feet.

To minimize reflections, the line should be terminated at both ends in its characteristic impedance, and stub lengths off the main line should be kept as short as possible.

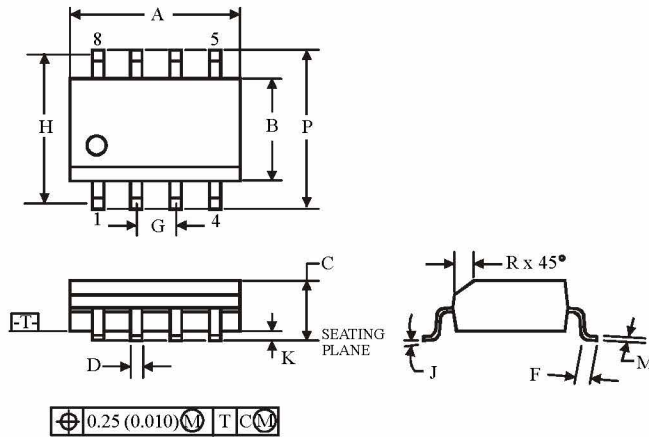

**Package Dimensions**
**SOIC 8**

Symbol	Dimension, mm	
	MIN	MAX
<b>A</b>	4.8	5
<b>B</b>	3.8	4
<b>C</b>	1.35	1.75
<b>D</b>	0.33	0.51
<b>F</b>	0.4	1.27
<b>G</b>	1.27	
<b>H</b>	5.72	
<b>J</b>	0°	8°
<b>K</b>	0.1	0.25
<b>M</b>	0.19	0.25
<b>P</b>	5.8	6.2
<b>R</b>	0.25	0.5

**NOTES:**

- Dimensions A and B do not include mold flash or protrusion.
- Maximum mold flash or protrusion 0.15 mm (0.006) per side for A; for B - 0.25 mm (0.010) per side.