

Fixed Frequency Current Mode PWM Controller

DESCRIPTION

Fixed frequency current-mode PWM controller. It is specially designed for Off Line And DC-to-DC converter applications with minimal external component. This integrated circuit features a trimmed oscillator for precise duty cycle control, a temperature compensated reference, high gain error amplifier, current sensing comparator, and a high current totempole output ideally suited for driving a power MOSFET.

Protection circuitry includes built in under-voltage lockout and current limiting.

FEATURES

- ◆ Automatic Feed Forward Compensation
- ◆ High Gain Totem Pole Output
- ◆ Internally Trimmed Bandgap Reference
- ◆ Undervoltage Lockout with Hysteresis
- ◆ Low Start Up Current
- ◆ Optimized for offline converter
- ◆ Double pulse suppression
- ◆ Current mode operation to 500KHz

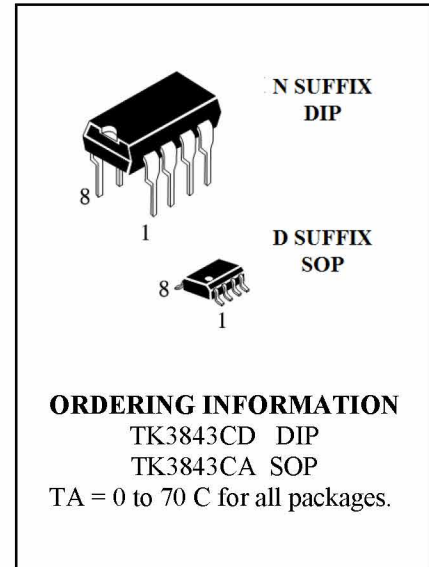

PIN CONNECTIONS

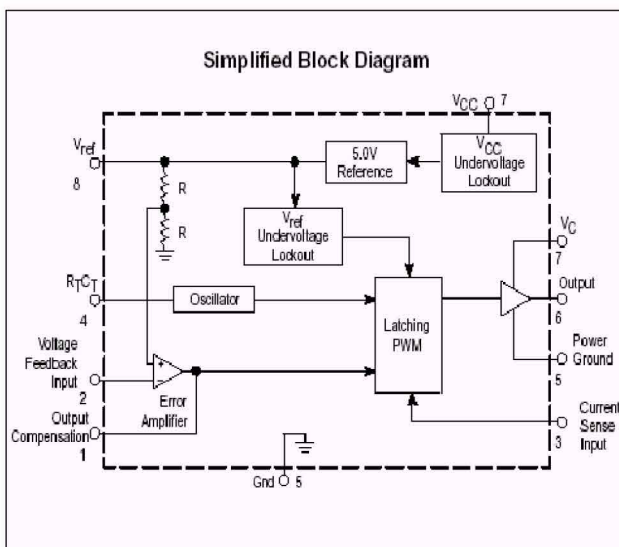
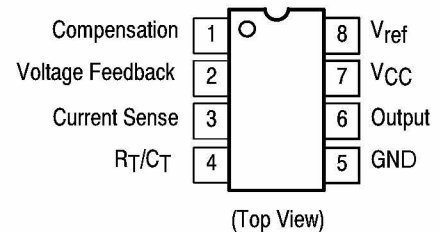

ORDERING INFORMATION

Device	Operating Temperature Range	Package
TK3843CD	T _A =0° to +70°C	DIP-8
TK3843CA	T _A =0° to +70°C	SOP-8

PIN FUNCTION DESCRIPTION

Pin No.	Function	Description
1	Compensation	This pin is the Error Amplifier output and is made available for loop compensation
2	Voltage Feedback	This is the inverting input of the Error Amplifier. It is normally connected to the switching power supply output through a resistor divider.
3	Current Sense	A voltage proportional to inductor current is connected to this input. The PWM uses this information to terminate the output switch conduction
4	RT/CT	The Oscillator frequency and maximum Output duty cycle are programmed by connecting resistor R_T to V_{REF} and capacitor C_T to ground. Operation to 500kHz is possible.
5	GND	This pin is the combined control circuitry and power ground
6	Output	This output directly drives the gate of a power MOSFET. Peak currents up to 1.0A are sourced and sunk by this pin.
7	Vcc	This pin is the positive supply of the control IC.
8	V_{REF}	This is the reference output. It provides charging current for capacitor C_T through resistor R_T

ABSOLUTE MAXIMUM RATINGS

Characteristic	Symbol	Value	Unit
Supply Voltage (low impedance source)	V_{CC}	30	V
Total Power Supply and Zener Current	$(I_{CC} + I_Z)$	30	mA
Output Current	I_O	± 1.0	A
Output Energy (Capacitive Load per Cycle)	W	5.0	μJ
Error Amp Output Sink Current	I_{OE}	10	mA
Current Sense and Voltage Feedback Inputs	V_{in}	-0.3 to 5.5	V
Maximum Power Dissipation @ $T_A = 25^\circ C$:			
DIP-8	P_D	0.862	W
SOP-8		0.625	
Thermal Resistance, Junction-to-Air	$R_{\theta JA}$	145	$^\circ C/W$
Operating Junction Temperature	T_J	+150	$^\circ C$
Storage Temperature Range	T_{stg}	-65 ~ +150	$^\circ C$

* Stresses beyond those listed under "absolute maximum ratings" may cause permanent damage to the device. These are stress ratings only and functional operation of the device at these or any other conditions beyond those indicated under "recommended operating conditions" is not implied. Exposure to absolute-maximum-rated conditions for extended periods may affect device reliability.

ELECTRICAL CHARACTERISTICS ($V_{CC}=15V$ unless otherwise noted)

Characteristics	Symbol	Min	Max	Unit
REFERENCE SECTION				
Reference Output Voltage ($I_O=1.0mA, V_{CC}=15V, T_A=25\pm 10^\circ C$) ($I_O=1.0mA, V_{CC}=15V, T_A=T_{low}$ to T_{high})	V_{ref}	4.9 4.865	5.1 5.135	V
Line Regulation ($V_{CC}=12V$ to $25V, T_A=T_{low}$ to T_{high})	Reg_{line}		20	mV
Load Regulation ($I_O=1.0$ to $20mA, T_A=T_{low}$ to T_{high})	Reg_{load}		25	mV
Total Output Variation over Line, Load, Temperature (Note1) ($V_{CC}=12V, I_O=1.0mA, T_A=T_{low}$ to T_{high}) ($V_{CC}=25V, I_O=20mA, T_A=T_{low}$ to T_{high})	V_{final}	4.82	5.18	V
Output Short Circuit Current ($V_{CC}=15V$)	I_{SC}	-30	-180	mA
OSCILLATOR SECTION				
Frequency ($V_{CC}=15V, T_j=25^\circ C, R_T=10k, C_T=3.3nF$) ($V_{CC}=15V, T_A=T_{low}$ to $T_{high}, R_T=10k, C_T=3.3nF$)	f_{osc}	47 46	57 60	kHz
Frequency Change with Voltage ($V_{CC}=12V$ to $25V, T_A=T_{low}$ to $T_{high}, R_T=10k, C_T=3.3nF$)	$\Delta f_{osc}/\Delta V$		1.0	%
Discharge Current ($V_{osc}=2.0V, V_{CC}=15V$) $T_j=25^\circ C$ $T_A=T_{low}$ to T_{high}	I_{disch}	7.5 7.2	9.3 9.5	mA
ERROR AMPLIFIER SECTION				
Voltage Feedback Input ($V_O=2.5V, V_{CC}=15V, T_A=T_{low}$ to T_{high})	V_{FB}	2.42	2.58	V
Input Bias Current ($V_{FB}=2.7V, V_{CC}=15V, T_A=T_{low}$ to T_{high})	I_{IB}		-2.0	μA
Open Loop Voltage Gain ($V_O=2.0V$ to $4.0V, V_{CC}=15V, T_A=T_{low}$ to T_{high})	A_{VOL}	65		dB
Unity Gain Bandwidth ($V_{CC}=15V, T_A=T_{low}$ to T_{high})	BW	0.7		MHz
Power Supply Rejection Ratio ($V_{CC}=12V$ to $25V, V_O=3.0V, T_A=T_{low}$ to T_{high})	PSRR	60		dB
Output Current Sink ($V_O=1.1V, V_{FB}=2.7V, V_{CC}=15V, T_A=T_{low}$ to T_{high}) Source ($V_O=5.0V, V_{FB}=2.3V, V_{CC}=15V, T_A=T_{low}$ to T_{high})	I_{Sink} I_{Source}	2.0 -0.5		mA
Output Voltage Swing High State ($V_{FB}=2.3V, V_{CC}=15V, R_{L(GND)}=15k, T_A=T_{low}$ to T_{high}) Low State ($V_{FB}=2.7V, V_{CC}=15V, R_{L(5.0)}=15k, T_A=T_{low}$ to T_{high})	V_{OH} V_{OL}	5.0	1.1	V
CURRENT SENSE SECTION				
Current Sense Input Voltage Gain ($V_{FB}=0V, V_{CC}=15V, T_A=T_{low}$ to T_{high})	A_v	2.85	3.15	V/V
Maximum Current Sense Input Threshold ($V_{FB}=0V, V_{CC}=15V, T_A=T_{low}$ to T_{high})	V_{th}	0.9	1.1	V
Input Bias Current ($V_{CC}=15V, T_A=T_{low}$ to T_{high})	I_{IB}		-10	μA
Propagation Delay (Current Sense Input to Output) ($V_{CC}=15V, T_A=T_{low}$ to T_{high})	t_{PLH}		300	ns

ELECTRICAL CHARACTERISTICS (V_{CC}=15V unless otherwise noted)

Characteristics	Symbol	Min	Max	Unit
OUTPUT SECTION				
Output Voltage Low State (Sink=20mA, V _{CC} =15V) (Sink=200mA, V _{CC} =15V) High State (Sink=-20mA, V _{CC} =15V) (Sink=-200mA, V _{CC} =15V)	V _{OL} V _{OH}	 13 12	 0.4 2.2	 V
Output Voltage with UVLO Activated (V _{CC} =6.0V, I _{Sink} =1.0mA, T _A =Tlow to Thigh)	V _{OL(UVLO)}		1.1	V
Output Voltage Rise Time (C _L =1.0nF, V _{CC} =15V, T _A =Tlow to Thigh)	tr		150	ns
Output Voltage Fall Time (C _L =1.0nF, V _{CC} =15V, T _A =Tlow to Thigh)	tf		150	ns
UNDERVOLTAGE LOCKOUT SECTION				
Startup Threshold (V _{CC} =0V to 15V, T _A =Tlow to Thigh)	V _{th}	7.8	9.0	V
Minimum Operating Voltage After Turn-On (V _{CC} =15V to 0V, T _A =Tlow to Thigh)	V _{CC(min)}	7.0	8.2	V
PWM SECTION				
Duty Cycle Maximum (V _{CC} =15V, T _A =Tlow to Thigh, R _T =10k, C _T =3.3nF) Minimum (V _{CC} =15V, T _A =Tlow to Thigh, R _T =10k, C _T =3.3nF)	DC _{max} DC _{min}	94	0	%
TOTAL DEVICE				
Power Supply Current Startup: V _{CC} =6.5V V _{CC} =15V Operating	I _{CC}		1.0 17	mA
Power Supply Zener Voltage (I _{CC} =25mA, V _{CC} =0 to 40V)	V _Z	30	40	V

NOTES: 1. $V_{final} = V_{ref25} \pm (Reg_{line} + Reg_{load})/1000 \pm |V_{ref70}(V_{ref0}) - V_{ref25}|$
 $V_{ref25} = V_{ref} @ T_A = 25^\circ C;$
 $V_{ref70} = V_{ref} @ T_A = 70^\circ C;$
 $V_{ref0} = V_{ref} @ T_A = 0^\circ C.$

2. Tlow= 0°C ; Thigh=+70°C

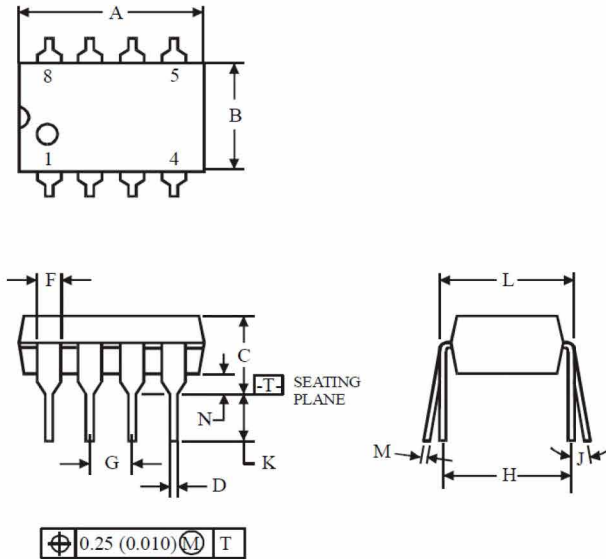
N SUFFIX DIP

	Dimension, mm	
Symbol	MIN	MAX
A	8.51	10.16
B	6.10	7.11
C		5.33
D	0.36	0.56
F	1.14	1.78
G	2.54	
H	7.62	
J	0°	10°
K	2.92	3.81
L	7.62	8.26
M	0.20	0.36
N	0.38	

NOTES:

- Dimensions "A", "B" do not include mold flash or protrusions.
Maximum mold flash or protrusions 0.25 mm (0.010) per side.

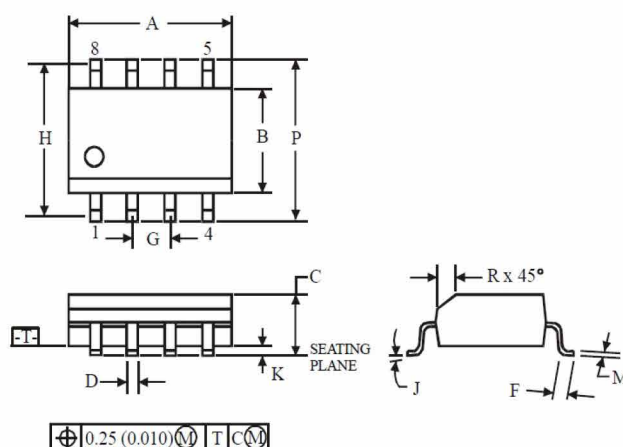
D SUFFIX SOP

	Dimension, mm	
Symbol	MIN	MAX
A	4.80	5.00
B	3.80	4.00
C	1.35	1.75
D	0.33	0.51
F	0.40	1.27
G	1.27	
H	5.72	
J	0°	8°
K	0.10	0.25
M	0.19	0.25
P	5.80	6.20
R	0.25	0.50

NOTES:

- Dimensions A and B do not include mold flash or protrusion.
- Maximum mold flash or protrusion 0.15 mm (0.006) per side for A; for B - 0.25 mm (0.010) per side.