

Low-Power, Slew-Rate-Limited RS-485/ RS-422 Transceivers

■ Description

The TK3486 is low-power transceivers for RS-485 and RS-422 communication. IC contains one driver and one receiver. The driver slew rates of the TK3486 is not limited, allowing them to transmit up to 2.5Mbps.

These transceivers draw between 120 μ A and 500 μ A of supply current when unloaded or fully loaded with disabled drivers. All parts operate from a single 3.3V supply. Drivers are short-circuit current limited and are protected against excessive power dissipation by thermal shutdown circuitry that places the driver outputs into a high-impedance state. The receiver input has a fail-safe feature that guarantees a logic-high output if the input is open circuit. We also designed a class of advanced devices with ESD protection.

■ Features

- Low Quiescent Current: 300 μ A
- -7V to +12.5V Common-Mode Input Voltage Range
- Three-State Outputs
- 48ns Propagation Delays, 11ns Skew
- Half-Duplex Versions Available
- Operate from a Single 3.3V Supply
- Allows up to 32 Transceivers on the Bus
- Data rate: 2.5Mbps
- Current-Limiting and Thermal Shutdown for Driver Overload Protection
- Enhanced ESD Specifications: ("EC" and "EE" only)
 - ±15kV IEC61000-4-2 Air Discharge
 - ±8kV IEC61000-4-2 Contact Discharge

■ ORDERING INFORMATION

Part Number	Package	Packing	Temperature(TA)	Package Qty
TK3486CSA	SOIC-8	Reel	0°C ~ 70°C	2500
TK3486ESA	SOIC-8	Reel	-40°C ~ 85°C	2500
TK3486ECSA	SOIC-8	Reel	0°C ~ 70°C	2500
TK3486EESA	SOIC-8	Reel	-40°C ~ 85°C	2500

Note: Please contact us to customize DIP packaging device.

■ Pin Assignment

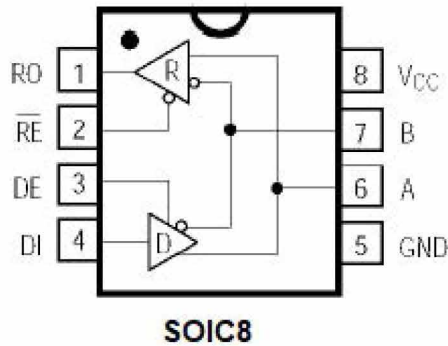

■ Pin Description

PIN NO.	PIN NAME	DESCRIPTION
1	RO	Receiver Output. If $A > B$ by 200mV, RO will be high; if $A < B$ by 200mV, RO will be low.
2	\overline{RE}	Receiver Output Enable. RO is enabled when \overline{RE} is low; RO is high impedance when \overline{RE} is high. If \overline{RE} is high and DE is low, the device will enter a low-power shutdown mode.
3	DE	Driver Output Enable. The driver outputs are enabled by bringing DE high. They are high impedance when DE is low. If \overline{RE} is high and DE is low, the device will enter a low-power shutdown mode. If the driver outputs are enabled, the parts function as line drivers. While they are high impedance, they function as line receivers if \overline{RE} is low.
4	DI	Driver Input. A low on DI forces output Y low and output Z high. Similarly, a high on DI forces output Y high and output Z low.
5	GND	Ground
6	A	Noninverting Receiver Input and Noninverting Driver Output
7	B	Inverting Receiver Input and Inverting Driver Output
8	Vcc	Positive Supply: $3.0V \leq VCC \leq 3.6V$

■ ABSOLUTE MAXIMUM RATINGS

Supply Voltage (V_{CC}) 7V	Continuous Power Dissipation ($T_A = +70^\circ\text{C}$)
Control Input Voltage -0.3V to 7V	8-Pin DIP (derate 9.09mW/ $^\circ\text{C}$ above $+70^\circ\text{C}$) 727mW
Driver Input Voltage (DI) -0.3V to 7V	8-Pin SOIC (derate 5.88mW/ $^\circ\text{C}$ above $+70^\circ\text{C}$) 471mW
Driver Output Voltage (A, B) -7.5V to +12.5V	Operating Temperature Ranges -40°C to $+85^\circ\text{C}$
Receiver Input Voltage (A, B) -7.5V to +12.5V	Storage Temperature Range -65°C to $+160^\circ\text{C}$
Receiver Output Voltage (RO) -0.3V to ($V_{CC}+0.3V$)	Lead Temperature (soldering, 10sec) $+300^\circ\text{C}$

* Stresses beyond those listed under "absolute maximum ratings" may cause permanent damage to the device. These are stress ratings only and functional operation of the device at these or any other conditions beyond those indicated under "recommended operating conditions" is not implied. Exposure to absolute-maximum-rated conditions for extended periods may affect device reliability.

■ DC ELECTRICAL CHARACTERISTICS

($V_{CC} = 3.3V \pm 0.3V$, $T_A = T_{MIN}$ to T_{MAX} , unless otherwise noted.) (Notes 1, 2)

PARAMETER	SYMBOL	CONDITIONS	MIN	TYP	MAX	UNITS
Differential Driver Output (no load)	V_{OD1}				3	V
Differential Driver Output (with load)	V_{OD2}	R = 100 Ω (RS-422)	1			V
		R = 54 Ω (RS-485), Figure 4	0.8			
Change in Magnitude of Driver Differential Output Voltage for Complementary Output States	ΔV_{OD}	R = 54 Ω or 50 Ω , Figure 4			0.2	V
Driver Common-Mode Output Voltage	V_{OC}	R = 54 Ω or 100 Ω , Figure 4			2	V
Change in Magnitude of Driver Common-Mode Output Voltage for Complementary Output States	ΔV_{OC}	R = 54 Ω or 100 Ω , Figure 4			0.2	V
Input High Voltage	V_{IH}	DE, DI, \overline{RE}	2.0			V
Input Low Voltage	V_{IL}	DE, DI, \overline{RE}			0.8	V
Input Current	I_{IN1}	DE, DI, \overline{RE}			± 2	μA
Input Current (A, B)	I_{IN2}	DE = 0V; $V_{CC} = 0V$ or 3.35V	$V_{IN} = 12V$		1.0	mA
			$V_{IN} = -7V$		-0.8	
Receiver Differential Threshold Voltage	V_{TH}	$-7V \leq V_{CM} \leq 12V$	-0.2		0.2	V
Receiver Input Hysteresis	ΔV_{TH}	$V_{CM} = 0V$		70		mV
Receiver Output High Voltage	V_{OH}	$I_O = -1.5\text{mA}$, $V_{ID} = 200\text{mV}$	2.5			V
Receiver Output Low Voltage	V_{OL}	$I_O = 2.5\text{mA}$, $V_{ID} = -200\text{mV}$			0.4	V
Three-State (high impedance) Output Current at Receiver	I_{OZR}	$0.4V \leq V_O \leq 2.4V$			± 1	μA
Receiver Input Resistance	R_{IN}	$-7V \leq V_{CM} \leq 12V$	12			k Ω

■ DC ELECTRICAL CHARACTERISTICS (continued)
 $(V_{CC} = 3.3V \pm 0.3V, T_A = T_{MIN} \text{ to } T_{MAX}, \text{ unless otherwise noted.})$ (Notes 1, 2)

PARAMETER	SYMBOL	CONDITIONS	MIN	TYP	MAX	UNITS
No-Load Supply Current (Note 3)	I _{CC}	DE = V _{CC}		500	800	μA
		RE = 0V or V _{CC}		300	400	
		DE = 0V				
Driver Short-Circuit Current,	I _{OSD1}	-7V ≤ V _O ≤ 12V (Note 4)			250	mA
V _O = High Driver Short-Circuit Current	I _{OSD2}	-7V ≤ V _O ≤ 12V (Note 4)			250	mA
V _O = Low Receiver Short-Circuit Current	I _{OSR}	0V ≤ V _O ≤ V _{CC}	±6.5		95	mA
ESD Protection		A, B, Y and Z pins, tested using Human Body Model		±15		kV

■ SWITCHING CHARACTERISTICS
 $(V_{CC} = 3.3V \pm 0.3V, T_A = T_{MIN} \text{ to } T_{MAX}, \text{ unless otherwise noted.})$ (Notes 1, 2)

PARAMETER	SYMBOL	CONDITIONS	MIN	TYP	MAX	UNITS
Driver Input to Output	t _{PLH}	R _{DIFF} = 54Ω	10	48	80	ns
	t _{PHL}	C _{L1} = C _{L2} = 100pF	10	48	80	
Driver Output Skew to Output	t _{SKEW}	R _{DIFF} = 54Ω, C _{L1} = C _{L2} = 100pF		11	20	ns
Driver Enable to Output High	t _{ZH}	C _L = 100pF, S2 closed		55	80	ns
Driver Enable to Output Low	t _{ZL}	C _L = 100pF, S1 closed		55	80	ns
Driver Disable Time from Low	t _{LZ}	C _L = 15pF, S1 closed		60	90	ns
Driver Disable Time from High	t _{HZ}	C _L = 15pF, S2 closed		60	90	ns
t _{PLH} - t _{PHL} Differential	t _{SKD}	R _{DIFF} = 54Ω		13	20	ns
Receiver Input to Output	t _{PLH}	R _{DIFF} = 54Ω	20	120	200	ns
	t _{PHL}	C _{L1} = C _{L2} = 100pF	20	120	200	
Receiver Skew t _{PLH} - t _{PHL}		C _{L1} = C _{L2} = 100pF		11	20	ns
Receiver Enable to Output Low	t _{ZL}	C _{RL} = 15pF, S1 closed		50	90	ns
Receiver Enable to Output High	t _{ZH}	C _{RL} = 15pF, S2 closed		50	90	ns
Receiver Disable Time from Low	t _{LZ}	C _{RL} = 15pF, S1 closed		40	80	ns
Receiver Disable Time from High	t _{HZ}	C _{RL} = 15pF, S2 closed		40	80	ns
Maximum Data Rate	f _{MAX}		1	2.5		Mbps

Note 1: All currents into device pins are positive; all currents out of device pins are negative. All voltages are referenced to device ground unless otherwise specified.

Note 2: All typical specifications are given for V_{CC}=3.3V and T_A=+25°C.

Note 3: Supply current specification is valid for loaded transmitters when DE=0V.

Note 4: Applies to peak current.

■ TEST CIRCUITS

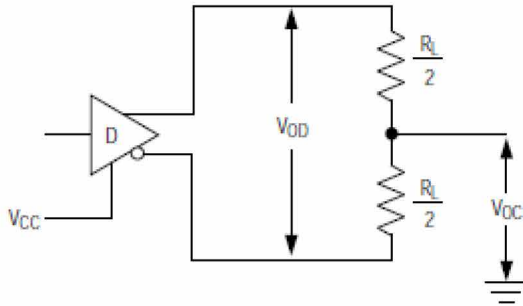

Figure 1. Driver V_{OD} and V_{OC}

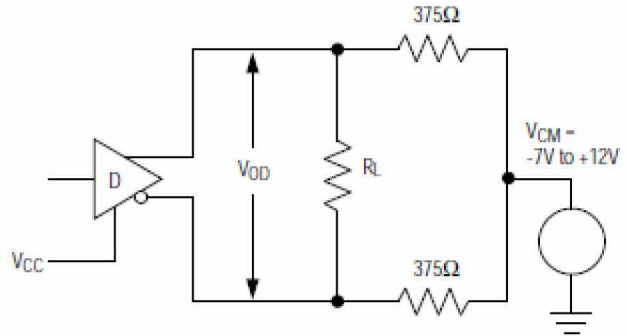

Figure 2. Driver V_{OD} with Varying Common-Mode Voltage

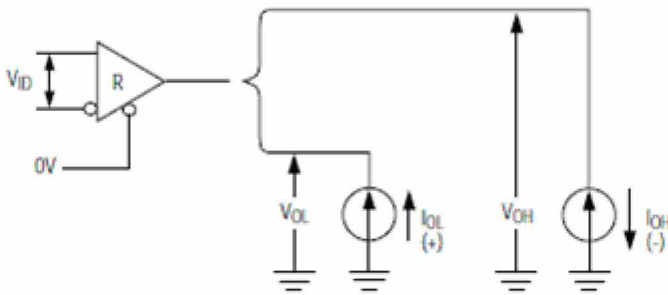

Figure 3. Receiver V_{OH} and V_{OL}

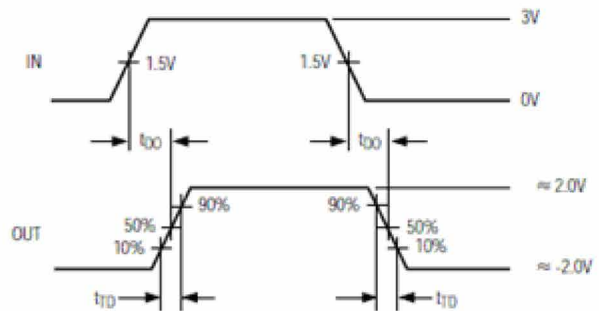
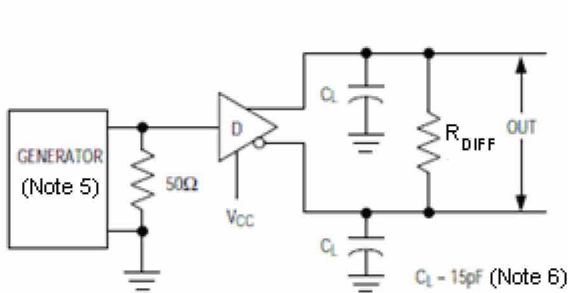

Figure 4. Driver Differential Output Delay and Transition Times

■ TEST CIRCUITS (continue)

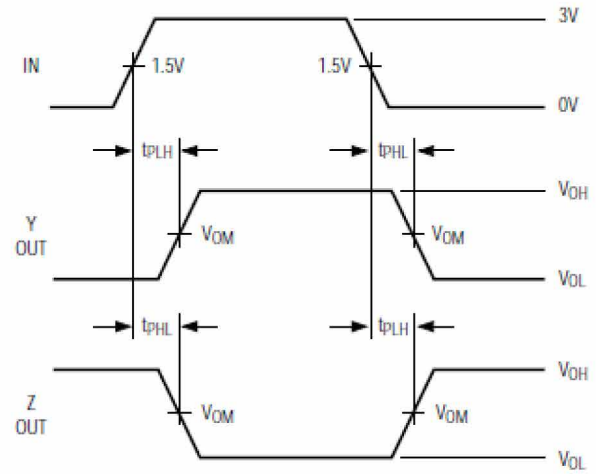
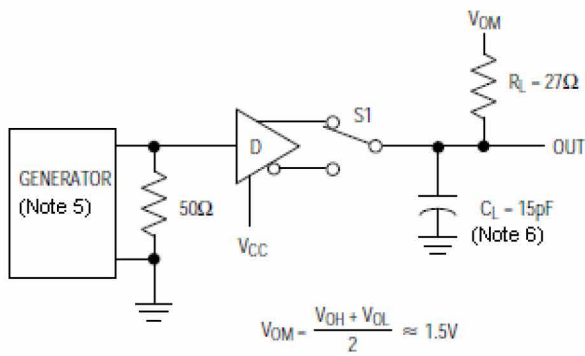

Figure 5. Driver Propagation Times

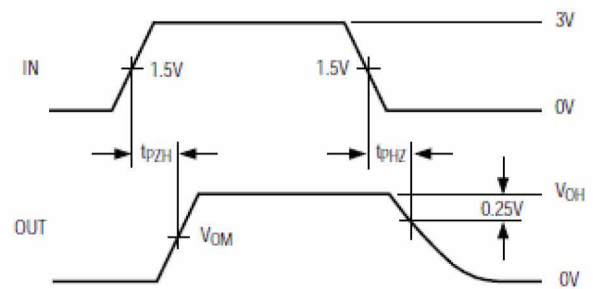
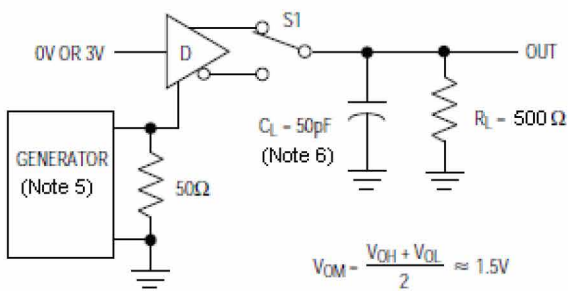

Figure 6. Driver Enable and Disable Times (t_{PZH} , t_{PSH} , t_{PHZ})

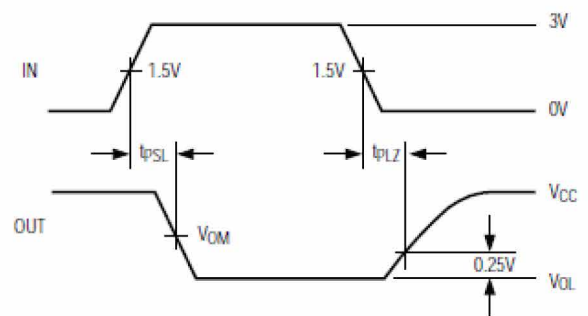
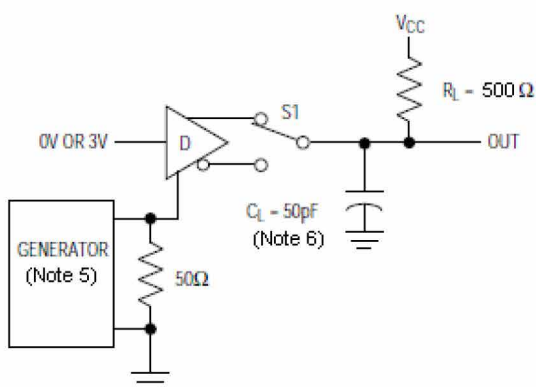

Figure 7. Driver Enable and Disable Times (t_{PZL} , t_{PSL} , t_{PLZ})

■ TEST CIRCUITS (continue)

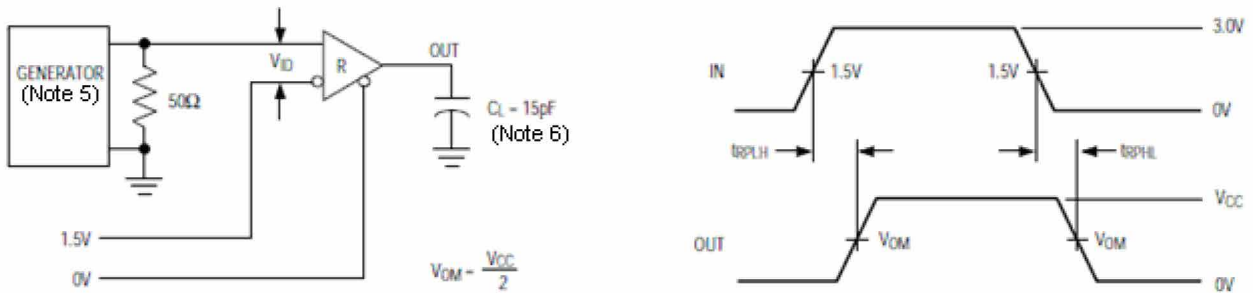

Figure 8. Receiver Propagation Delay

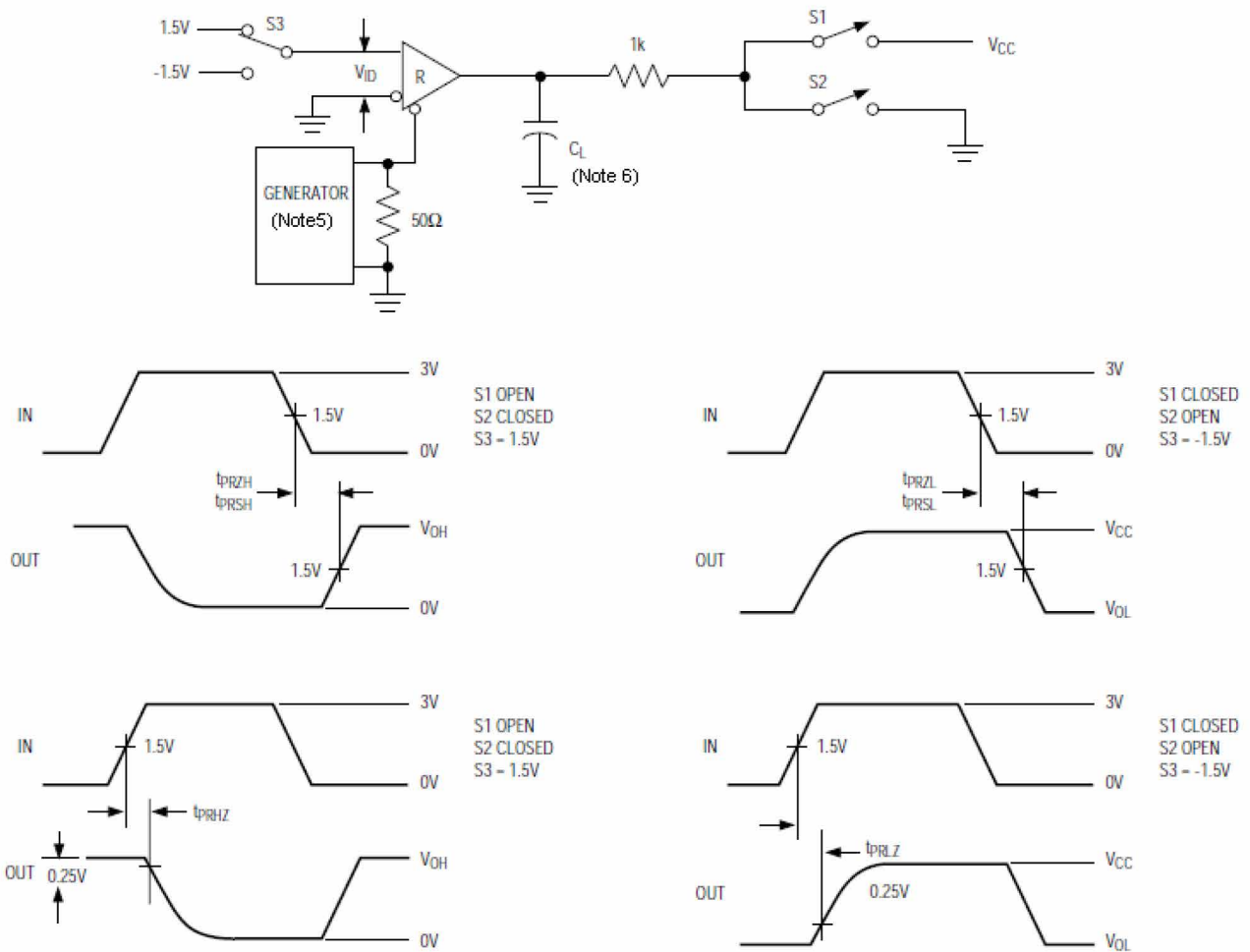

Figure 9. Receiver Enable and Disable Times

Note 5: The input pulse is supplied by a generator with the following characteristics: PRR = 250kHz, 50% duty cycle, $t_r \leq 6.0\text{ns}$, $Z_o = 50\Omega$.

Note 6: C_L includes probe and stray capacitance.

■ Function Tables

Transmitting				
INPUTS			OUTPUTS X	
\overline{RE}	DE	DI	Z	Y
X	1	1	0	1
X	1	0	1	0
0	0	X	Z	Z
1	0	X	Z	Z

Receiving			
INPUTS			OUTPUTS
\overline{RE}	DE	A-B	RO
0	0	+0.2V	1
0	0	-0.2V	0
0	0	open	1
1	0	X	Z

X-don't care
 Z-high impedance

■ Typical Information

Figure 10. TK3486 Typical RS-485 Network

Driver Output Protection

Excessive output current and power dissipation caused by faults or by bus contention are prevented by two mechanisms. A foldback current limit on the output stage provides immediate protection against short circuits over the whole common-mode voltage range. In addition, a thermal shutdown circuit forces the driver outputs into a high-impedance state if the die temperature rises excessively.

Propagation Delay

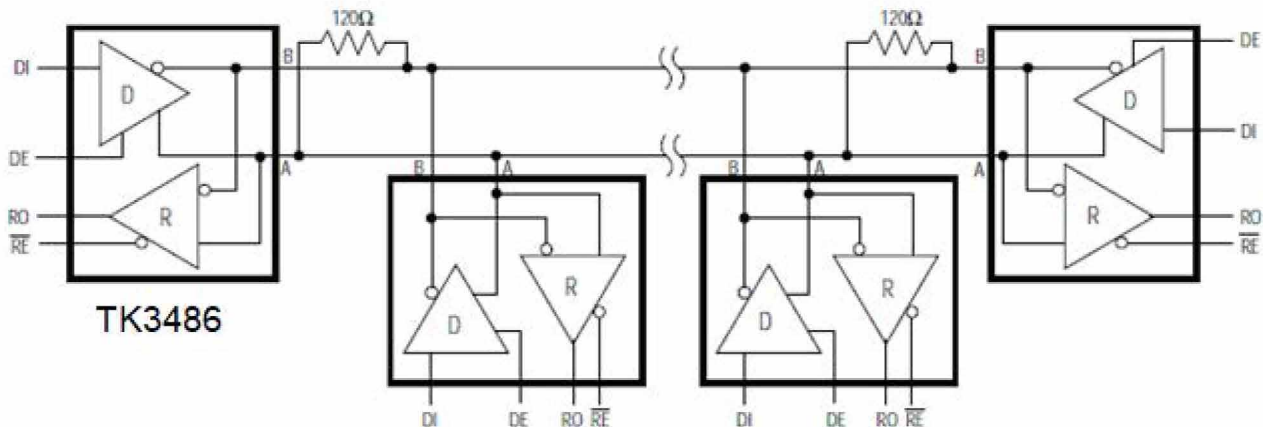
Skew time is simply the difference between the low-to-high and high-to-low propagation delay. Small driver/receiver skew times help maintain a symmetrical mark-space ratio (50% duty cycle).

The receiver skew time, $|t_{PRLH} - t_{PRHL}|$, is under 20ns. The driver skew times are 11ns for the TK3486.

Typical Applications

TK3486 transceivers are designed for bidirectional data communications on multipoint bus transmission lines. Figure 10 shows typical network applications circuits. These parts can also be used as line repeaters, with cable lengths longer than 4000 feet.

To minimize reflections, the line should be terminated at both ends in its characteristic impedance, and stub lengths off the main line should be kept as short as possible.

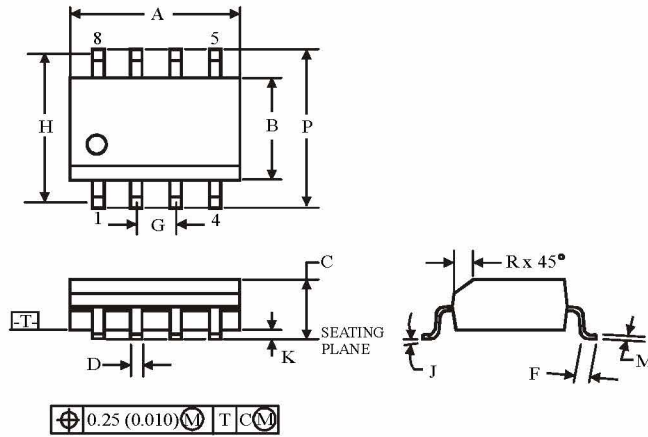
■ Package Dimensions
SOIC8

Symbol	Dimension, mm	
	MIN	MAX
A	4.8	5
B	3.8	4
C	1.35	1.75
D	0.33	0.51
F	0.4	1.27
G	1.27	
H	5.72	
J	0°	8°
K	0.1	0.25
M	0.19	0.25
P	5.8	6.2
R	0.25	0.5

NOTES:

1. Dimensions A and B do not include mold flash or protrusion.
2. Maximum mold flash or protrusion 0.15 mm (0.006) per side for A; for B - 0.25 mm (0.010) per side.