

Interface Transceiver of RS-232 Standard with One Supply Voltage

■ DESCRIPTION

The TK3232 is a 3.3V powered EIA/TIA-232 and V.28/V.24 communication interface with low power requirements, high data-rate capabilities. TK3232 has a proprietary low dropout transmitter output stage providing true RS-232 performance from 3.3V to 5.5V supplies. The device requires only four small 0.1 μ F standard external capacitors for operations from 3.3V supply.

The TK3232 has two receivers and two drivers. The device is guaranteed to run at data rates of 120Kbps while maintaining RS-232 output levels. Typical applications are Notebook, Subnotebook and Palmtop Computers, Battery Powered Equipment, Hand-Held Equipment, Peripherals and Printers.

■ FEATURES

- 300 μ A SUPPLY CURRENT
- CHARGE PUMP CIRCUITRY ELIMINATES THE NEED FOR A BIPOLAR \pm 12V SUPPLY
- 120Kbps GUARENTEED DATA RATE
- 3V/ μ s MINIMUM GUARANTEED SLEW RATE
- WIDE SINGLE-SUPPLY OPERATION FROM +3V TO +5.5V
- ENHANCED ESD SPECIFICATIONS(EC and EE_ only):
 - \pm 15kV IEC61000-4-2 Air Discharge
 - \pm 8kV IEC61000-4-2 Contact Discharge

■ APPLICATIONS

- Battery-Powered Equipment
- Hand-Held Equipment
- Peripherals
- Datacom Equipment

■ ORDERING INFORMATION

Part Number	Package	Packing	Temperature(TA)	Package Qty	ESD
TK3232CSE	SOIC-16	Reel	0°C ~ 70°C	2500	-
TK3232ESE	SOIC-16	Reel	-40°C ~ 85°C	2500	-
TK3232ECSE	SOIC-16	Reel	0°C ~ 70°C	2500	\pm 15KV
TK3232EESE	SOIC-16	Reel	-40°C ~ 85°C	2500	\pm 15KV

Note: Please contact us to customize DIP/SSOP packaging device.

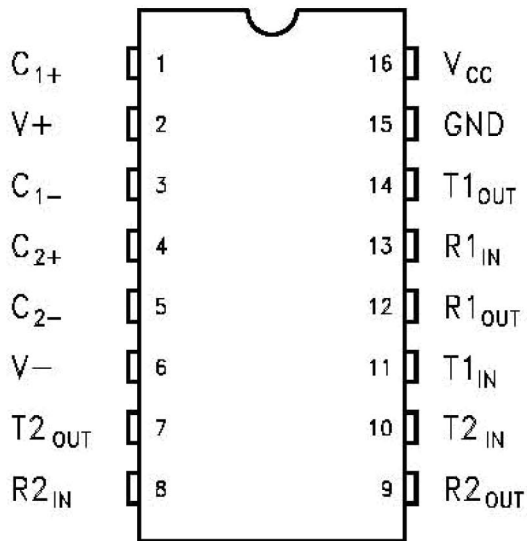
■ PIN ASSIGNMENT

■ PIN DESCRIPTION

PIN N°	SYMBOL	NAME AND FUNCTION
1	C1+	Positive Terminal for the first Charge Pump Capacitor
2	V+	Doubled Voltage Terminal
3	C1-	Negative Terminal for the first Charge Pump Capacitor
4	C2+	Positive Terminal for the second Charge Pump Capacitor
5	C2-	Negative Terminal for the second Charge Pump Capacitor
6	V-	Inverted Voltage Terminal
7	T2OUT	Second Transmitter Output Voltage
8	R2IN	Second Receiver Input Voltage
9	R2OUT	Second Receiver Output Voltage
10	T2IN	Second Transmitter Input Voltage
11	T1IN	First Transmitter Input Voltage
12	R1OUT	First Receiver Output Voltage
13	R1IN	First Receiver Input Voltage
14	T1OUT	First Transmitter Output Voltage
15	GND	Ground
16	Vcc	Supply Voltage

■ ABSOLUTE MAXIMUM RATING

Symbol	Parameter	Value	Unit
V _{CC}		-0.3 to 6	V
V ₊		(V _{CC} - 0.3) to 7	V
V ₋	Inverted Voltage Terminal	0.3 to -7	V
V ₊ + V ₋		13	V
T _{IN}		-0.3 to 6	V
R _{IN}	Receiver Input Voltage Range	± 25	V
T _{OUT}	Transmitter Output Voltage Range	± 13.2	V
R _{OUT}	Receiver Output Voltage Range	-0.3 to (V _{CC} + 0.3)	V
T _a	Operating Temperature	-40 to 85	°C
T _s	Storage Temperature	-60 to 150	°C
t _{SHORT}	Transmitter Output Short to GND Time	Continuous	

* Stresses beyond those listed under “absolute maximum ratings” may cause permanent damage to the device.

These are stress ratings only and functional operation of the device at these or any other conditions beyond those indicated under “recommended operating conditions” is not implied.

Exposure to absolute-maximum-rated conditions for extended periods may affect device reliability.

V₊ and V₋ can have a maximum magnitude of +7V, but their absolute addition cannot exceed 13 V.

■ ELECTRICAL CHARACTERISTICS

($C_1 - C_4 = 0.1\mu\text{F}$, $V_{CC} = 3.3\text{V}$ to 5.5V , $T_A = -40$ to 85°C , unless otherwise specified.
 Typical values are referred to $T_A = 25^\circ\text{C}$)

Symbol	Parameter	Test Conditions	Min.	Typ.	Max.	Unit
I _{SUPPLY}	VCC Power Supply Current	No Load $V_{CC} = 3.3\text{V} \pm 10\%$ $T_A = 25^\circ\text{C}$		2.5	5	mA
		No Load $V_{CC} = 5\text{V} \pm 10\%$ $T_A = 25^\circ\text{C}$		6	10	mA

■ LOGIC INPUT ELECTRICAL CHARACTERISTICS

($C_1 - C_4 = 0.1\mu\text{F}$, $V_{CC} = 3.3\text{V}$ to 5.5V , $T_A = -40$ to 85°C , unless otherwise specified.
 Typical values are referred to $T_A = 25^\circ\text{C}$)

Symbol	Parameter	Test Conditions	Min.	Typ.	Max.	Unit
V _{TIL}	Input Logic Threshold Low	T-IN (Note 1)			0.8	V
V _{TIH}	Input Logic Threshold High	$V_{CC} = 3.3\text{V}$	2			V
		$V_{CC} = 5\text{V}$	2.4			V
I _{IL}	Input Leakage Current	T-IN		± 0.01	± 1	μA

Note1: Transmitter input hysteresis is typically 250mV

■ TRANSMITTER ELECTRICAL CHARACTERISTICS

($C_1 - C_4 = 0.1\mu\text{F}$ tested at $V_{CC} = 3.3\text{V}$ to 5.5V , $T_A = -40$ to 85°C , unless otherwise specified.
 Typical values are referred to $T_A = 25^\circ\text{C}$)

Symbol	Parameter	Test Conditions	Min.	Typ.	Max.	Unit
V _{TOUT}	Output Voltage Swing	All Transmitter outputs are loaded with 3K Ω to GND				
		$V_{CC} = 5.0\text{V}$	± 5	± 5.4		V
			± 3.5	± 4.0		
R _{TOUT}	Transmitter Output Resistance	$V_{CC} = V+ = V- = 0\text{V}$ $V_{OUT} = \pm 2\text{V}$	300	10M		Ω
I _{TSC}	Output Short Circuit Current	$V_{CC} = 3.3\text{V}$ to 5V $V_{OUT} = 0\text{V}$			± 60	mA

■ RECEIVER ELECTRICAL CHARACTERISTICS

($C_1 - C_4 = 0.1\mu\text{F}$ tested at $V_{CC} = 3.3\text{V}$ to 5.5V , $T_A = -40$ to 85°C , unless otherwise specified.
 Typical values are referred to $T_A = 25^\circ\text{C}$)

Symbol	Parameter	Test Conditions	Min.	Typ.	Max.	Unit
V _{RIN}	Receiver Input Voltage Operating Range		-25		25	V
V _{RIL}	RS-232 Input Threshold Low	$T_A = 25^\circ\text{C}$ $V_{CC} = 3.3\text{V}$	0.6	1.2		V
		$T_A = 25^\circ\text{C}$ $V_{CC} = 5\text{V}$	0.8	1.5		V
V _{RIH}	RS-232 Input Threshold High	$T_A = 25^\circ\text{C}$ $V_{CC} = 3.3\text{V}$		1.5	2.4	V
		$T_A = 25^\circ\text{C}$ $V_{CC} = 5\text{V}$		1.8	2.4	V
V _{RIHYS}	Input Hysteresis			0.3		V
R _{RIN}	Input Resistance	$T_A = 25^\circ\text{C}$	3	5	7	k Ω
V _{ROL}	TTL/CMOS Output Voltage Low	I _{OUT} = 1.6mA $V_{CC} = 3.3\text{V}$			0.4	V
		I _{OUT} = 3.2mA $V_{CC} = 5.5\text{V}$				V
V _{ROH}	TTL/CMOS Output Voltage High	I _{OUT} = -0.5mA $V_{CC} = 3.3\text{V}$	V _{CC} -0.6	V _{CC} -0.1		V
		I _{OUT} = -1mA $V_{CC} = 5.5\text{V}$				V

■ TIMING CHARACTERISTICS

($C_1 - C_4 = 0.1\mu\text{F}$, $V_{CC} = 3.3\text{V}$ to 5.5V , $T_A = -40$ to 85°C , unless otherwise specified.
 Typical values are referred to $T_A = 25^\circ\text{C}$)

Symbol	Parameter	Test Conditions	Min.	Typ.	Max.	Unit
D_R	Data Transfer Rate	$R_L = 3\text{K}\Omega$ $C_{L2} = 1000\text{pF}$ one transmitter switching $V_{CC} = 3.3\text{V}$		120	235	Kbps
t_{PHLR} t_{PLHR}	Propagation Delay Input to Output	$R_{XIN} = R_{XOUT}$ $C_L = 150\text{pF}$		4.0	9.7	μs
t_{PHLT} t_{PLHT}	Propagation Delay Input to Output	$R_L = 3\text{K}\Omega$ $C_L = 2500\text{pF}$		2.0	5.0	μs
$ t_{PHLR} - t_{PLHR} $	Receiver Propagation Delay Difference			300		ns
$ t_{PHLT} - t_{PLHT} $	Transmitter Propagation Delay Difference			300		ns
S_{RT}	Transition Slew Rate	$T_A = 25^\circ\text{C}$ $R_L = 3\text{K}\Omega$ to $7\text{K}\Omega$ measured from $+3\text{V}$ to -3V or -3V to $+3\text{V}$ $C_L = 150\text{pF}$ to 1000pF	3		30	$\text{V}/\mu\text{s}$

Transmitter Skew is measured at the transmitter zero cross points

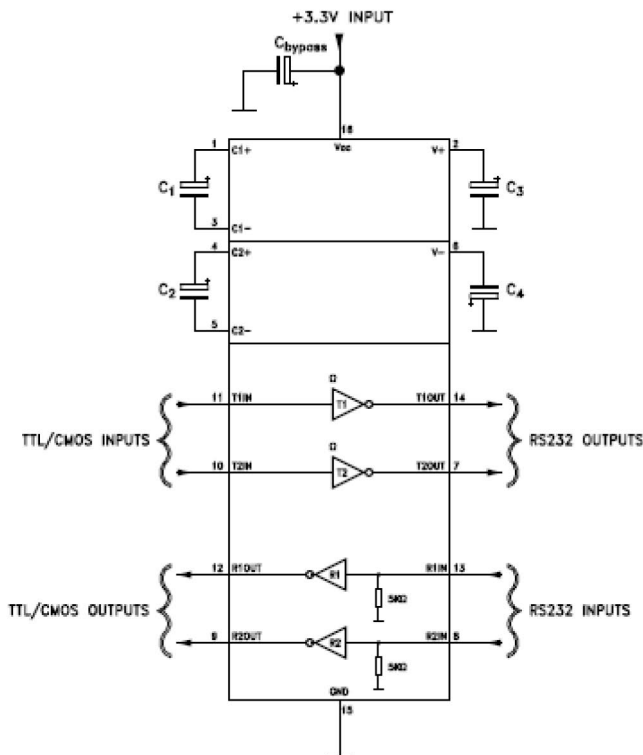
■ APPLICATION CIRCUITS

CAPACITANCE VALUE (μF)

V_{CC}	C1	C2	C3	C4	C_{bypass}
3.0 to 5.5	1.0	1.0	1.0	1.0	1.0

■ **TYPICAL OPERATING CHARACTERISTICS**

(VCC = +3.3V, 120kbps data rate, 0.1μF capacitors, all transmitters loaded with 3kΩ, TA = +25° C, unless otherwise noted.)

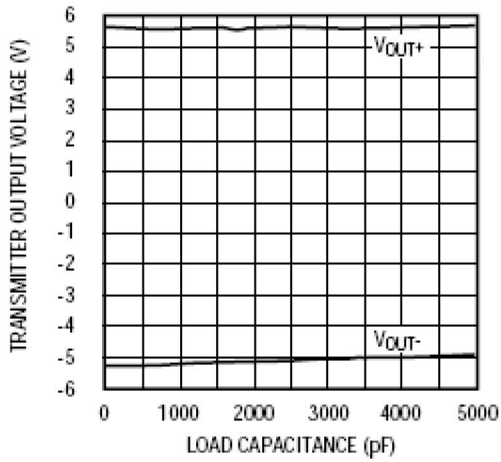

TRANSMITTER OUTPUT VOLTAGE vs. LOAD CAPACITANCE

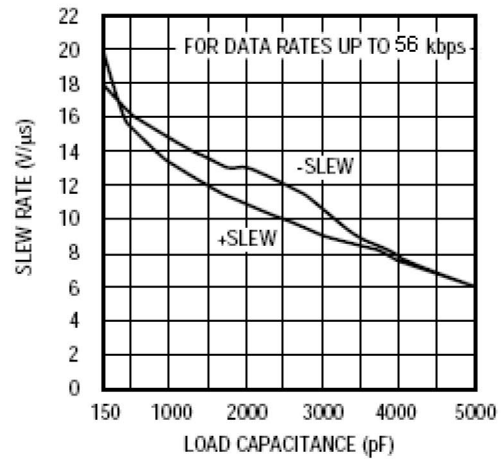

SLEW RATE vs. LOAD CAPACITANCE

■ ESD PROTECTION

The TK3232 incorporates ruggedized ESD cells on all driver output and receiver input pins. The ESD structure is for rugged applications and environments sensitive to electro-static discharges and associated transients. The ESD tolerance is at least $\pm 15\text{kV}$ without damage or latch-up.

There are different methods of ESD testing applied:

- a) MIL-STD-883, Method 3015.7
- b) IEC1000-4-2 Air-Discharge

The Human Body Model has been the generally accepted ESD testing method for semiconductors. This method is also specified in MIL-STD- 883, Method 3015.7 for ESD testing. The premise of this ESD test is to simulate the human body's potential to store electro-static energy and discharge it to an integrated circuit. The simulation is performed by using a test model as shown in *Figure 1*. This method will test the IC's capability to withstand an ESD transient during normal handling such as in manufacturing areas where the ICs tend to be handled frequently.

The IEC-1000-4-2, formerly IEC801-2, is generally used for testing ESD on equipment and systems. For system manufacturers, they must guarantee a certain amount of ESD protection since the system itself is exposed to the outside environment and human presence. The premise with IEC1000-4-2 is that the system is required to withstand an amount of static electricity when ESD is applied to points and surfaces of the equipment that are accessible to personnel during normal usage. The transceiver IC receives most of the ESD current when the ESD source is applied to the connector pins. The test circuit for IEC1000-4-2 is shown on *Figure 2*. There are two methods within IEC1000-4-2, the Air Discharge method and the Contact Discharge method.

With the Air Discharge Method, an ESD voltage is applied to the equipment under test (EUT) through air. This simulates an electrically charged person ready to connect a cable onto the rear of the system only to find an unpleasant zap just before the person touches the back panel. The high energy potential on the person discharges through an arcing path to the rear panel of the system before he or she even touches the system. This energy, whether discharged directly or through air, is predominantly a function of the discharge current rather than the discharge voltage. Variables with an air discharge such as approach speed of the object carrying the ESD potential to the system and humidity will tend to change the discharge current. For example, the rise time of the discharge current varies with the approach speed.

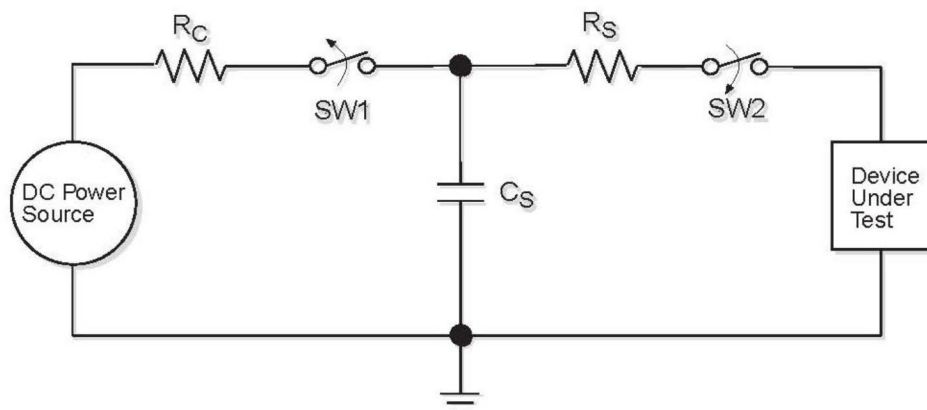

Fig. 1 ESD Test Circuit for Human Body Model

The Contact Discharge Method applies the ESD current directly to the EUT. This method was devised to reduce the unpredictability of the ESD arc. The discharge current rise time is constant since the energy is directly transferred without the air-gap arc. In situations such as hand held systems, the ESD charge can be directly discharged to the equipment from a person already holding the equipment. The current is transferred on to the keypad or the serial port of the equipment directly and then travels through the PCB and finally to the IC.

The circuit models in *Figures 1 and 2* represent the typical ESD testing circuits used for these methods. The CS is initially charged with the DC power supply when the first switch (SW1) is on. Now that the capacitor is charged, the second switch (SW2) is on while SW1 switches off. The voltage stored in the capacitor is then applied through RS, the current limiting resistor, onto the device under test (DUT). In ESD tests, the SW2 switch is pulsed so that the device under test receives a duration of voltage.

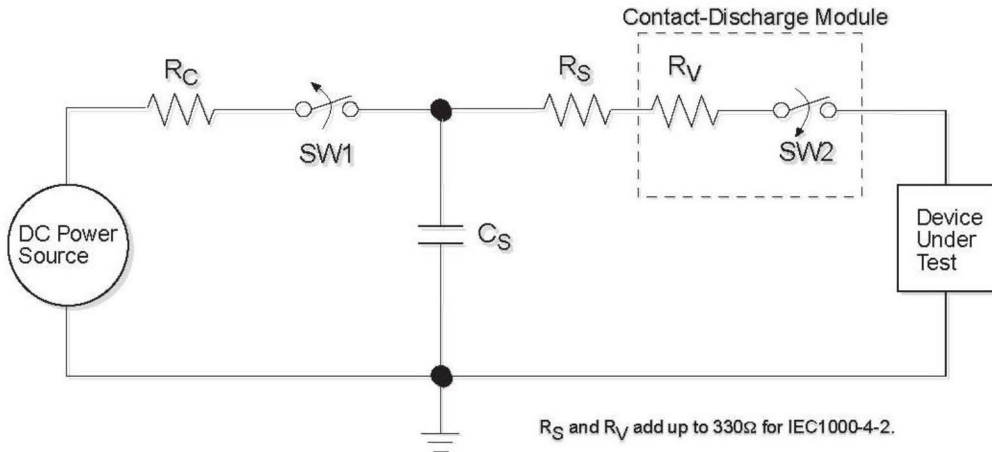

Fig. 2. ESD Test Circuit for IEC1000-4-2

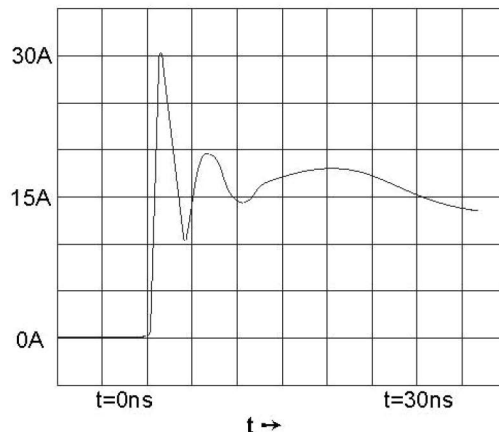
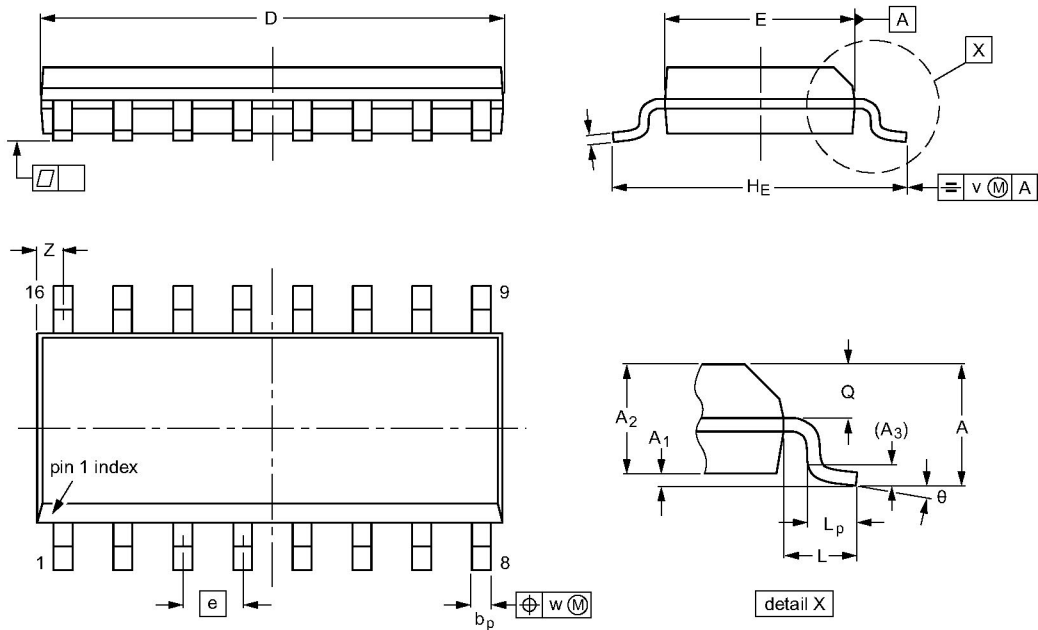

Fig. 3. ESD Test Waveform for IEC1000-4-2

For the Human Body Model, the current limiting resistor (R_S) and the source capacitor (C_S) are 1.5kΩ and 100pF, respectively. For IEC-1000-4-2, the current limiting resistor (R_S) and the source capacitor (C_S) are 330Ω and 150pF, respectively. The higher C_S value and lower R_S value in the IEC1000-4-2 model are more stringent than the Human Body Model. The larger storage capacitor injects a higher voltage to the test point when SW2 is switched on. The lower current limiting resistor increases the current charge onto the test point.

Device Pin Tested	IEC1000-4-2	
	Air Discharge	Level
Driver Outputs	±15kV	4
Receiver Inputs	±15kV	4

SOIC16: plastic small outline package; 16 leads; body width 3.9 mm

DIMENSIONS (mm are the original dimensions)

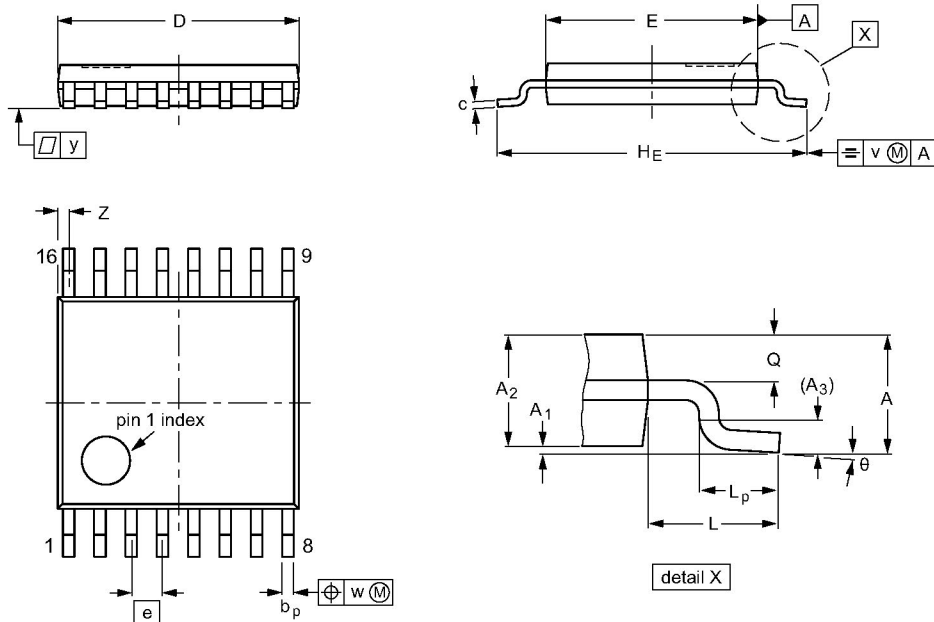
UNIT	A max.	A ₁	A ₂	A ₃	b _p	c	D ⁽¹⁾	E ⁽¹⁾	e	H _E	L	L _p	Q	v	w	y	Z ⁽¹⁾	θ
mm	1.75	0.25 0.10	1.45 1.25	0.25	0.49 0.36	0.25 0.19	10.0 9.8	4.0 3.8	1.27	6.2 5.8	1.05	1.0 0.4	0.7 0.6	0.25	0.25	0.1	0.7 0.3	8° 0

TSSOP16: plastic thin shrink small outline package; 16 leads; body width 4.4 mm

DIMENSIONS (mm are the original dimensions)

UNIT	A max.	A ₁	A ₂	A ₃	b _p	c	D ⁽¹⁾	E ⁽²⁾	e	H _E	L	L _p	Q	v	w	y	Z ⁽¹⁾	θ
mm	1.1	0.15 0.05	0.95 0.80	0.25	0.30 0.19	0.2 0.1	5.1 4.9	4.5 4.3	0.65	6.6 6.2	1	0.75 0.50	0.4 0.3	0.2	0.13	0.1	0.40 0.06	8° 0°