

Interface Transceiver of the Serial Data of the Standard RS-485/RS-422

■ Description

The TK3086 is interface transceiver of serial data under RS-485 standard with low power consumption. The TK3086 features reduced slew-rate drivers that minimize EMI and reduce reflections caused by improperly terminated cables, allowing error-free data transmission up to 10Mbps. It is intended for full-duplex communications.

The TK3086 is purposed for application in telecom systems under RS485/RS422 standards with low power dissipation, translators of the level, transceiving devices sensitive to electromagnetic radiation, industrial control systems.

■ Features

- 1 transmitter and 1 receiver of the serial data of the standard RS-485
- Auto Shutdown function provide low power consumption
- Supply voltage range: $5.0V \pm 5\%$
- Operating temperature range: $-40 \sim +85^{\circ}C$
- Data rate: 10Mbps
- ESD protection up to 2000V for transmitter input and receiver output (TTL/CMOS levels) and up to 15000V for transmitter output and receiver input (RS-485 levels)
- Latch current, min – 300mA at normal climatic condition
- Enhanced ESD Specifications(EC&EE_ only):
 - ±15kV IEC61000-4-2 Air Discharge
 - ±8kV IEC61000-4-2 Contact Discharge

■ Ordering Information

Part Number	Package	Packing	Temperature(TA)	Package Qty	ESD
TK3086CSD	SOIC-14	Reel	$0^{\circ}C \sim 70^{\circ}C$	2500	
TK3086ESD	SOIC-14	Reel	$-40^{\circ}C \sim 85^{\circ}C$	2500	
TK3086ECSD	SOIC-14	Reel	$0^{\circ}C \sim 70^{\circ}C$	2500	±15KV
TK3086EESD	SOIC-14	Reel	$-40^{\circ}C \sim 85^{\circ}C$	2500	±15KV

Note: Please contact us to customize DIP packaging device.

■ Pin Description

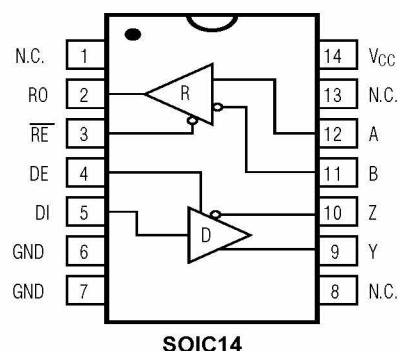
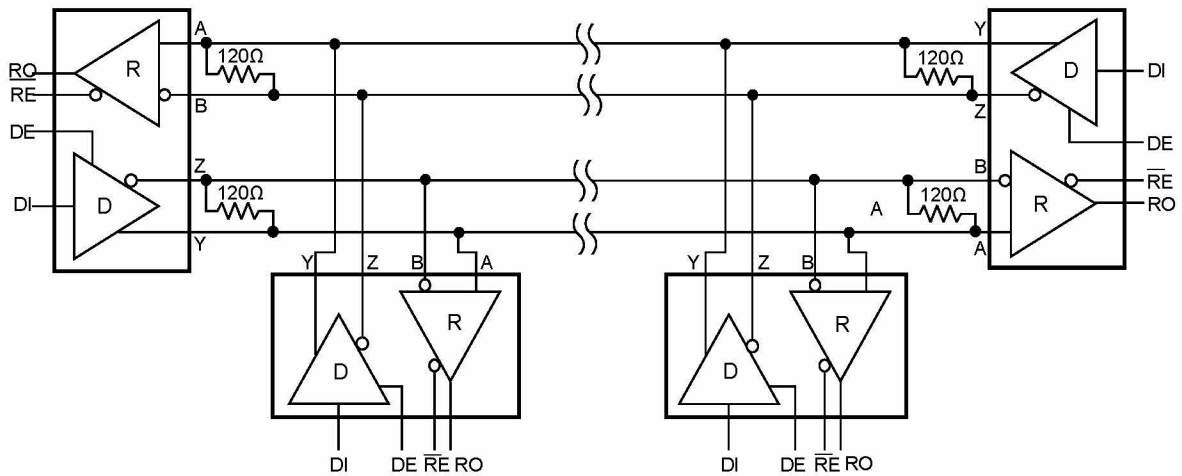

Table 1. Pin Description

Pin Num	Symbol	Pin Description
01	N.C.	No Connect. Not internally connected, can be connected to GND.
02	RO	Receiver Output. When \overline{RE} is low and if $A - B \geq -50\text{mV}$, RO will be high; if $A - B \leq -200\text{mV}$, RO will be low.
03	\overline{RE}	Receiver Output Enable. Drive \overline{RE} low to enable RO; RO is high impedance when \overline{RE} is high. Drive \overline{RE} high and DE low to enter low-power shutdown mode.
04	DE	Driver Output Enable. Drive DE high to enable driver outputs. These outputs are high impedance when DE is low. Drive \overline{RE} high and DE low to enter low-power shutdown mode.
05	DI	Driver Input. With DE high, a low on DI forces noninverting output low and inverting output high. Similarly, a high on DI forces noninverting output high and inverting output low.
06	GND	Ground
07	GND	Ground
08	N.C.	No Connect. Not internally connected, can be connected to GND.
09	Y	Noninverting Driver Output
10	Z	Inverting Driver Output
11	B	Inverting Receiver Input
12	A	Noninverting Receiver Input
13	N.C.	No Connect. Not internally connected, can be connected to GND.
14	V _{CC}	Positive Supply; $4.75\text{V} \leq V_{CC} \leq 5.25\text{V}$

Typical Full-Duplex RS-485 Network Application Diagram

Table 2. Transmitter Truth Table

TRANSMITTING				
INPUTS			OUTPUTS	
$\overline{\text{RE}}$	DE	DI	Z	Y
X	H	H	L	H
X	H	L	H	L
L	L	X	High-Z	High-Z
H	L	X	Shutdown	

Note : H – high level, L – low level , X –don't care, Z – third state

Table 3. Receiver Truth Table

RECEIVING			
INPUTS			OUTPUT
$\overline{\text{RE}}$	DE	A-B	RO
L	X	$\geq -0.05\text{V}$	H
L	X	$\leq -0.2\text{V}$	L
L	X	Open/shorted	H
H	H	X	High-Z
H	L	X	Shutdown

Note : H – high level, L – low level , BH – inputs not used, X –don't care, Z – third state,
 ZZ – inputs and outputs are in the third state

Table 4. Maximum Ratings

Parameter	Limit		Unit
	min	max	
Supply Voltage (V_{CC})		7.0	V
Control Input Voltage (\overline{RE} , DE)	-0.3	$V_{CC} + 0.3$	V
($\overline{H/\overline{F}}$, SRL, TXP, RXP)	0.3	$V_{CC} + 0.3$	V
Driver Input Voltage (DI)	0.3	$V_{CC} + 0.3$	V
Driver Output Voltage (A, B, Y, Z)	-13	13	V
Receiver Input Voltage, Full Duplex (A, B)	-25	25	V
Receiver Output Voltage (RO)	0.3	$V_{CC} + 0.3$	V
Continuous Power Dissipation ($T_A = +70^\circ\text{C}$)		667	mW

Table 5. Electrical Parameters

 (V_{CC} = 5V ± 5%)

PARAMETER	SYMBOL	CONDITIONS		MIN	TYP	MAX	UNITS
DRIVER							
Differential Driver Output (no load)	V _{OD1}	Fig 5				5	V
Differential Driver Output	V _{OD2}	Fig 1, R = 50Ω (RS-422)		2.0			V
		Fig 1, R = 27Ω (RS-485)		1.5			
Change in Magnitude of Differential Output Voltage	ΔV _{OD}	Fig 1, R = 50Ω or R = 27Ω				0.2	V
Driver Common-Mode Output Voltage	V _{OC}	Fig 1, R = 50Ω or R = 27Ω				3	V
Change In Magnitude of Common-Mode Voltage)	ΔV _{OC}	Fig 1, R = 50Ω or R = 27Ω				0.2	V
Input High Voltage	V _{IH1}	DE, DI, \overline{RE} , H/ \overline{F} , TXP, RXP		2.0			V
Input Low Voltage	V _{IL1}	DE, DI, \overline{RE} , H/ \overline{F} , TXP, RXP				0.8	V
DI Input Hysteresis	V _{HYS}	TK3080–TK3085, and TK3089 with SRL = V _{CC} or unconnected			100		mV
SRL Input Current	I _{IN1}	DE, DI, \overline{RE}				±2	μA
	I _{IN2}	H/ \overline{F} , TXP, RXP, internal pulldown		10		40	
Input High Voltage	V _{IH2}	SRL		V _{CC} - 0.8			V
Input Middle Voltage	V _{IM2}	SRL		0.4V _{CC}		0.6V _{CC}	V
Input Low Voltage	V _{IL2}	SRL				0.8	V
SRL Input Current	I _{IN3}	SRL = V _{CC}				75	μA
		SRL = GND		-75			
Input Current (A and B) Full Duplex	I _{IN4}	DE = GND, V _{CC} = GND or 5.25V	V _{IN} = 12V			125	μA
			V _{IN} = -7V			-75	
Output Leakage (Y and Z) Full Duplex	I _O	DE = GND, V _{CC} = GND or 5.25V	V _{IN} = 12V			125	μA
			V _{IN} = -7V	-100			
Driver Short-Circuit Output Current	V _{OD1}	-7V ≤ V _{OUT} ≤ V _{CC}		-250			mA
		0V ≤ V _{OUT} ≤ 12V				250	
		0V ≤ V _{OUT} ≤ V _{CC}		±25			
RECEIVER							
Receiver Differential Threshold Voltage	V _{TH}	-7V ≤ V _{CM} ≤ +12V		-200	-125	-50	mV
Receiver Input Hysteresis	ΔV _{TH}				25		mV
Receiver Output High Voltage	V _{OH}	I _O = -4mA, V _{ID} = -50mV		V _{CC} - 1.5			V
Receiver Output Low Voltage	V _{OL}	I _O = 4mA, V _{ID} = -200mV				0.4	V
Three-State Output Current at Receiver	I _{OZR}	0.4V ≤ V _O ≤ 2.4V				±1	μA
	R _{IN}			96			kΩ
Receiver Output Short-Circuit Current	I _{OSR}	0V ≤ V _{RO} ≤ V _{CC}		±7		±95	mA
SUPPLY CURRENT							
Supply Current	I _{CC}	No load, \overline{RE} = DI = GND or V _{CC} , SRL = V _{CC}	DE = V _{CC}	430	900		μA
			DE = GND	375	600		
		No load, \overline{RE} = DI = GND or V _{CC} , SRL = GND	DE = V _{CC}	475	1000		μA
			DE = GND	420	800		
Supply Current in Shutdown Mode	I _{SHDN}	DE = GND, \overline{VRE} = V _{CC}		0.001	10		μA
ESD Protection for Y, Z, A, B		Human Body Model (TK3086E_)			±15		kV

Table 6. SWITCHING CHARACTERISTICS

 (V_{CC} = +5V ±5%, T_A = T_{MIN} to T_{MAX}, Typical values are at V_{CC} = +5V and T_A = +25°C.)

PARAMETER	SYMBOL	CONDITIONS	MIN	TYP	MAX	UNITS
Driver Input to Output	t _{DPLH}	Fig 3 and 5, R _{DIFF} = 54Ω, C _{L1} = C _{L2} = 100pF	250	720	1000	ns
	t _{DPHL}		250	720	1000	
Driver Output Skew t _{DPLH} - t _{DPHL}	t _{DSKEW}	Fig 3 and 5, R _{DIFF} = 54Ω, C _{L1} = C _{L2} = 100pF		-3	±100	ns
Driver Rise or Fall Time	t _{DR} , t _{DF}	Fig 3 and 5, R _{DIFF} = 54Ω, C _{L1} = C _{L2} = 100pF	200	530	750	ns
Maximum Data Rate	f _{MAX}		500			kbps
Driver Enable to Output High	t _{DZH}	Fig 4 and 6, C _L = 100pF, S2 closed			2500	ns
Driver Enable to Output Low	t _{DZL}	Fig 4 and 6, C _L = 100pF, S1 closed			2500	ns
Driver Disable Time from Low	t _{DLZ}	Fig 4 and 6, C _L = 15pF, S1 closed			100	ns
Driver Disable Time from High	t _{DHZ}	Fig 4 and 6, C _L = 15pF, S2 closed			100	ns
Receiver Input to Output	t _{RPLH} , t _{RPHL}	Fig 7; V _{ID} ≥ 2.0V; rise and fall time of V _{ID} ≤ 15ns		127	200	ns
t _{RPLH} - t _{RPHL} Differential Receiver Skew	t _{RSKD}	Fig 7; V _{ID} ≥ 2.0V; rise and fall time of V _{ID} ≤ 15ns		3	±30	ns
Receiver Enable to Output Low	t _{RZL}	Fig 2 and 8, C _L = 100pF, S1 closed		20	50	ns
	t _{RZH}	Fig 2 and 8, C _L = 100pF, S2 closed		20	50	ns
Receiver Disable Time from Low	t _{RLZ}	Fig 2 and 8, C _L = 100pF, S1 closed		20	50	ns
Receiver Disable Time from High	t _{RHZ}	C _L = 100pF, S2 closed		20	50	ns
Time to Shutdown	t _{SHDN}	(Note 1)	50	200	600	ns
Driver Enable from Shutdown to Output High	t _{DZH(SHDN)}	Fig 4 and 6, C _L = 15pF, S2 closed			4500	ns
Driver Enable from Shutdown to Output Low	t _{DZL(SHDN)}	Fig 4 and 6, C _L = 15pF, S1 closed			4500	ns
Receiver Enable from Shutdown to Output High	t _{RZH(SHDN)}	Fig 2 and 8, C _L = 100pF, S2 closed			3500	ns
Receiver Enable from Shutdown to Output Low	t _{RZL(SHDN)}	Fig 2 and 8, C _L = 100pF, S1 closed			3500	ns

Note 1: The device is put into shutdown by bringing \overline{RE} high and DE low. If the enable inputs are in this state for less than 50ns, The device is guaranteed not to enter shutdown. If the enable inputs are in this state for at least 600ns, the device is guaranteed to have entered shutdown.

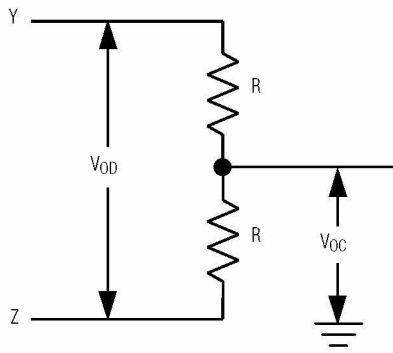

Fig 1. Driver DC Test Load

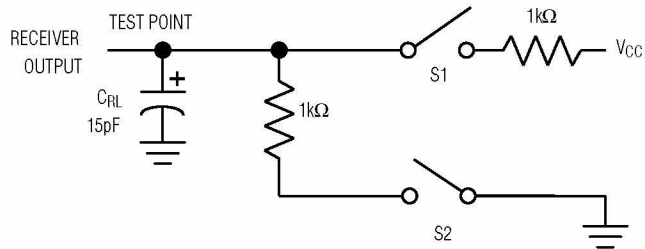

Fig 2. Receiver Enable/Disable Timing Test Load

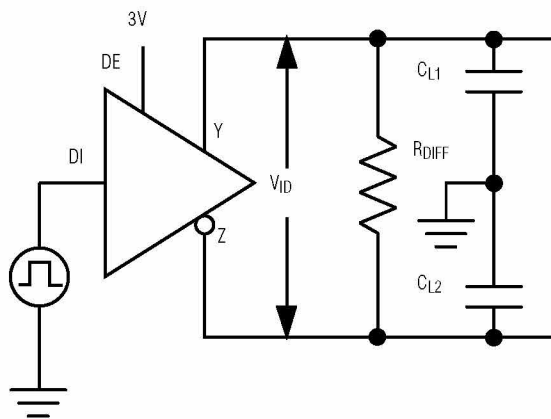

Fig 3. Driver Timing Test Circuit

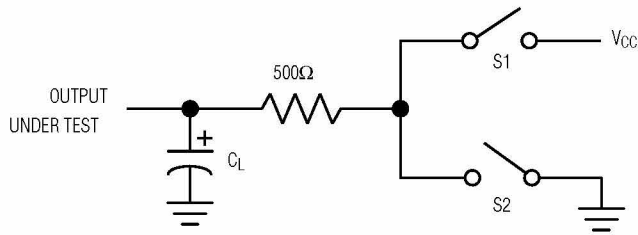

Fig 4 Driver Enable/Disable Timing Test Load

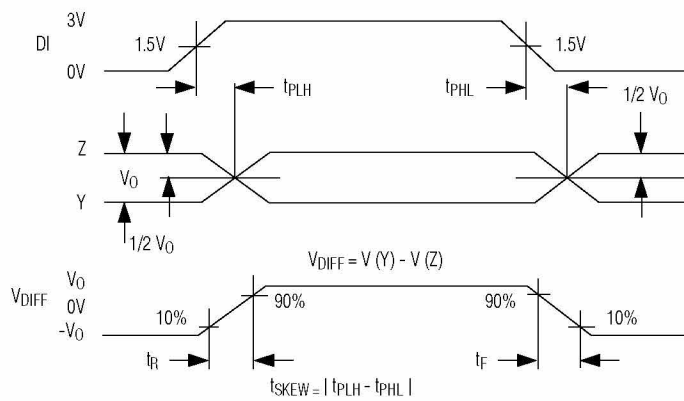

Fig 5. Driver Propagation Delays

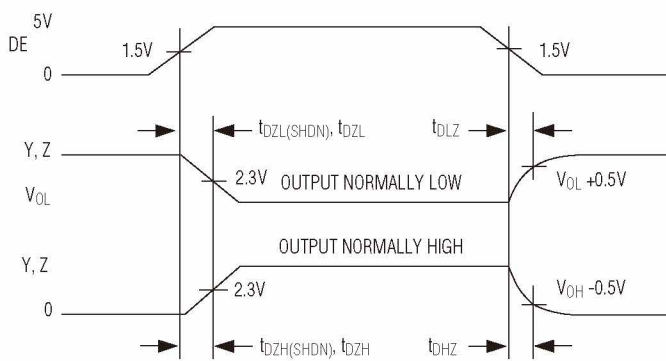

Fig 6. Driver Enable and Disable Times

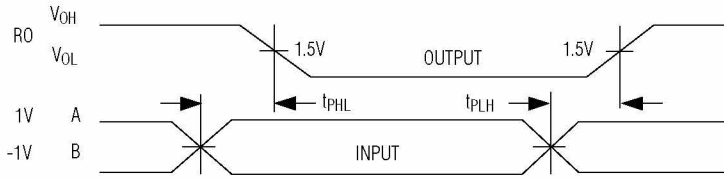

Fig 7. Receiver Propagation Delays

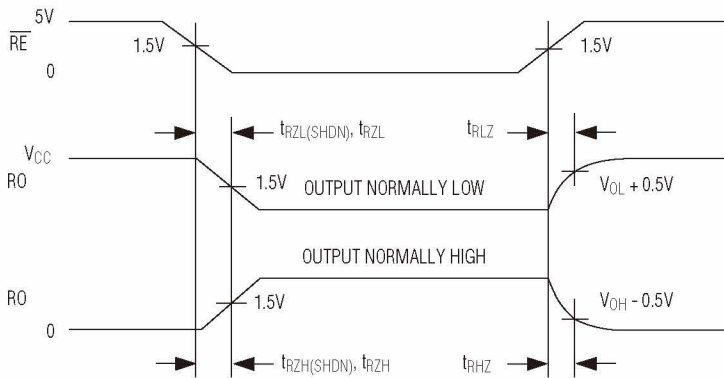

Fig 8. Receiver Enable and Disable Times

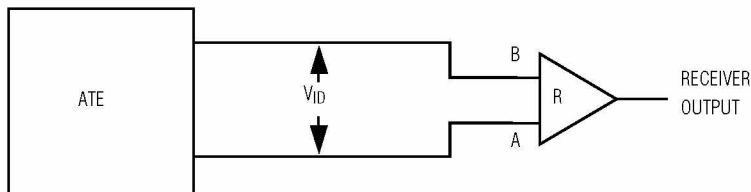

Fig 9. Receiver Propagation Delay Test Circuit

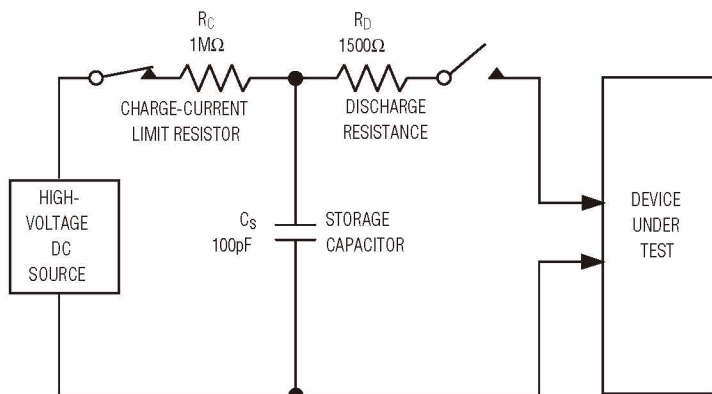

Fig 10. Human Body ESD Test Model

Package diagram

SOIC14: plastic small outline package; 14 leads; body width 3.9 mm

