

Fail-Safe,Slew-Rate-Limited RS-485/RS-422 Transceivers

■ Description

The TK3081 is interface transceiver of serial data under RS-485 standard with low power consumption. The TK3081 features reduced slew-rate drivers that minimize EMI and reduce reflections caused by improperly terminated cables, allowing error-free data transmission up to 115Kbps. It is intended for full-duplex communications.

The TK3081 is purposed for application in telecom systems under RS485/RS422 standards with low power dissipation, translators of the level, transceiving devices sensitive to electromagnetic radiation, industrial control systems.

■ Features

- Allows up to 256 transceivers on the bus
- Supply voltage range: $5.0V \pm 5\%$
- Data rate: 115Kbps
- Full-duplex communications
- Latch current, min – 300mA at normal climatic condition
- Enhanced ESD Specifications(TK3081E_ only):
 $\pm 15kV$ IEC61000-4-2 Air Discharge
 $\pm 8kV$ IEC61000-4-2 Contact Discharge

■ Ordering Information

Part Number	Package	Packing	Temperature(TA)	Package Qty	ESD
TK3081CSA	SOIC-8	Reel	0°C ~ 70°C	2500	
TK3081ESA	SOIC-8	Reel	-40°C ~ 85°C	2500	
TK3081ECSA	SOIC-8	Reel	0°C ~ 70°C	2500	$\pm 15KV$
TK3081EESA	SOIC-8	Reel	-40°C ~ 85°C	2500	$\pm 15KV$

Note: Please contact us to customize DIP packaging device.

■ Pin Description

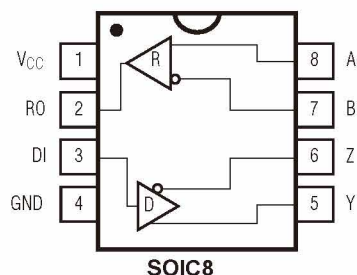

Table 1. Pin Description

Pin Num	Symbol	Pin Description
01	V _{CC}	Positive Supply $4.75V \leq V_{CC} \leq 5.25V$
02	RO	Receiver Output. When \overline{RE} is low and if $A - B \geq -50mV$, RO will be high; if $A - B \leq -200mV$, RO will be low.
03	DI	Driver Input. With DE high, a low on DI forces noninverting output low and inverting output high. Similarly, a high on DI forces non-inverting output high and inverting output low.
04	GND	Ground
05	Y	Noninverting Driver Output
06	Z	Inverting Driver Output
07	B	Inverting Receiver Input
08	A	Noninverting Receiver Input

Typical Full-Duplex Operating Circuit

Table 2. Transmitter Truth Table

TRANSMITTING		
INPUT	OUTPUTS	
DI	Z	Y
H	L	H
L	H	L

Note : H – high level, L – low level , X –don't care

Table 3. Receiver Truth Table

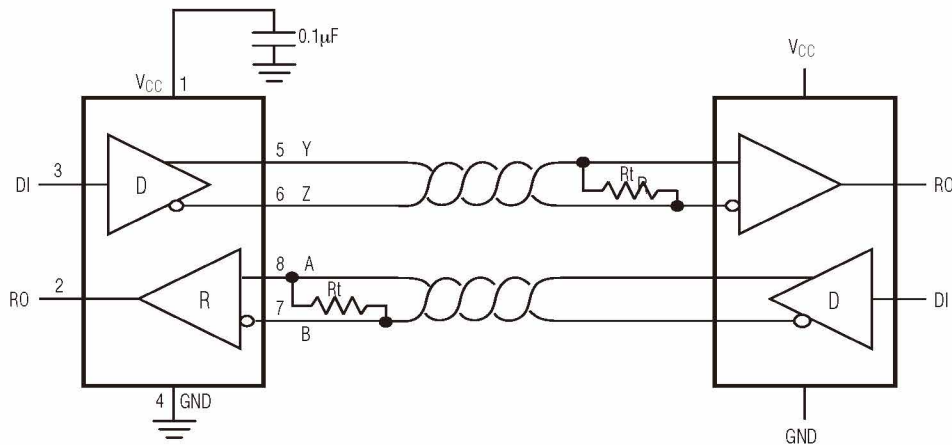
RECEIVING	
INPUTS	OUTPUT
A - B	RO
$\geq -0.05V$	H
$\leq -0.2V$	L
Open/shorted	H

Note : H – high level, L – low level , BH – inputs not used, X –don't care

Table 4. Maximum Ratings

Parameter	Limit		Unit
	min	max	
Supply Voltage (V _{CC})		7.0	V
Driver Input Voltage (DI)	0.3	V _{CC} + 0.3	V
Driver Output Voltage (A, B, Y, Z)	-13	13	V
Receiver Input Voltage, Full Duplex (A, B)	-25	25	V
Receiver Output Voltage (RO)	0.3	V _{CC} + 0.3	V
Continuous Power Dissipation (T _A = +70°C)		471	mW

Table 5. Electrical Parameters

 (V_{CC} = 5V ± 5%)

PARAMETER	SYMBOL	CONDITIONS		MIN	TYP	MAX	UNITS
DRIVER							
Differential Driver Output (no load)	V _{OD1}	Fig 1				5	V
Differential Driver Output	V _{OD2}	Fig 1, R = 50Ω (RS-422)		2.0			V
		Fig 1, R = 27Ω (RS-485)		1.5			
Change in Magnitude of Differential Output Voltage	ΔV _{OD}	Fig 1, R = 50Ω or R = 27Ω				0.2	V
Driver Common-Mode Output Voltage	V _{OC}	Fig 1, R = 50Ω or R = 27Ω				3	V
Change In Magnitude of Common-Mode Voltage)	ΔV _{OC}	Fig 1, R = 50Ω or R = 27Ω				0.2	V
Input High Voltage	V _{IH1}	DE, DI, \overline{RE} , H/ \overline{F} , TXP, RXP		2.0			V
Input Low Voltage	V _{IL1}	DE, DI, \overline{RE} , H/ \overline{F} , TXP, RXP				0.8	V
DI Input Hysteresis	V _{HYS}	TK3080–TK3085, and TK3089 with SRL = V _{CC} or unconnected			100		mV
SRL Input Current	I _{IN1}	DE, DI, \overline{RE}				±2	μA
	I _{IN2}	H/ \overline{F} , TXP, RXP, internal pulldown		10		40	
Input High Voltage	V _{IH2}	SRL		V _{CC} - 0.8			V
Input Middle Voltage	V _{IM2}	SRL		0.4V _{CC}		0.6V _{CC}	V
Input Low Voltage	V _{IL2}	SRL				0.8	V
SRL Input Current	I _{IN3}	SRL = V _{CC}				75	μA
		SRL = GND		-75			
Input Current (A and B) Full Duplex	I _{IN4}	DE = GND, V _{CC} = GND or 5.25V	V _{IN} = 12V			125	μA
			V _{IN} = -7V			-75	
Output Leakage (Y and Z) Full Duplex	I _O	DE = GND, V _{CC} = GND or 5.25V	V _{IN} = 12V			125	μA
			V _{IN} = -7V	-100			
Driver Short-Circuit Output Current	V _{OD1}	-7V ≤ V _{OUT} ≤ V _{CC}		-250			mA
		0V ≤ V _{OUT} ≤ 12V				250	
		0V ≤ V _{OUT} ≤ V _{CC}		±25			
RECEIVER							
Receiver Differential Threshold Voltage	V _{TH}	-7V ≤ V _{CM} ≤ +12V		-200	-125	-50	mV
Receiver Input Hysteresis	ΔV _{TH}				25		mV
Receiver Output High Voltage	V _{OH}	I _O = -4mA, V _{ID} = -50mV		V _{CC} - 1.5			V
Receiver Output Low Voltage	V _{OL}	I _O = 4mA, V _{ID} = -200mV				0.4	V
Three-State Output Current at Receiver	I _{OZR}	0.4V ≤ V _O ≤ 2.4V				±1	μA
	R _{IN}			96			kΩ
Receiver Output Short-Circuit Current	I _{OSR}	0V ≤ V _{RO} ≤ V _{CC}		±7		±95	mA
SUPPLY CURRENT							
Supply Current	I _{CC}	No load, \overline{RE} = DI = GND or V _{CC} , SRL = V _{CC}	DE = V _{CC}	430	900		μA
			DE = GND	375	600		
		No load, \overline{RE} = DI = GND or V _{CC} , SRL = GND	DE = V _{CC}	475	1000		μA
			DE = GND	420	800		
Supply Current in Shutdown Mode	I _{SHDN}	DE = GND, \overline{VRE} = V _{CC}		0.001		10	μA
ESD Protection for Y, Z, A, B		Human Body Model (TK3086E_)				±15	kV

Table 6. SWITCHING CHARACTERISTICS

 (V_{CC} = +5V ±5%, T_A = T_{MIN} to T_{MAX}, Typical values are at V_{CC} = +5V and T_A = +25°C.)

PARAMETER	SYMBOL	CONDITIONS	MIN	TYP	MAX	UNITS
Driver Input to Output	t _{DPLH}	Fig 3 and 5, R _{DIFF} = 54Ω, C _{L1} = C _{L2} = 100pF	500	2030	2600	ns
	t _{DPHL}		500	2030	2600	
Driver Output Skew t _{DPLH} - t _{DPHL}	t _{DSKEW}	Fig 3 and 5, R _{DIFF} = 54Ω, C _{L1} = C _{L2} = 100pF		-3	±200	ns
Driver Rise or Fall Time	t _{DR} , t _{DF}	Fig 3 and 5, R _{DIFF} = 54Ω, C _{L1} = C _{L2} = 100pF	667	1320	2500	ns
Maximum Data Rate	f _{MAX}		115			kbps
Driver Enable to Output High	t _{DZH}	Fig 4 and 6, C _L = 100pF, S2 closed			3500	ns
Driver Enable to Output Low	t _{DZL}	Fig 4 and 6, C _L = 100pF, S1 closed			3500	ns
Driver Disable Time from Low	t _{DLZ}	Fig 4 and 6, C _L = 15pF, S1 closed			100	ns
Driver Disable Time from High	t _{DHZ}	Fig 4 and 6, C _L = 15pF, S2 closed			100	ns
Receiver Input to Output	t _{RPLH} , t _{RPHL}	Fig 7; V _{ID} ≥ 2.0V; rise and fall time of V _{ID} ≤ 15ns		127	200	ns
t _{RPLH} - t _{RPHL} Differential Receiver Skew	t _{RSKD}	Fig 7; V _{ID} ≥ 2.0V; rise and fall time of V _{ID} ≤ 15ns		3	±30	ns
Receiver Enable to Output Low	t _{RZL}	Fig 2 and 8, C _L = 100pF, S1 closed		20	50	ns
Receiver Enable to Output High	t _{RZH}	Fig 2 and 8, C _L = 100pF, S2 closed		20	50	ns
Receiver Disable Time from Low	t _{RLZ}	Fig 2 and 8, C _L = 100pF, S1 closed		20	50	ns
Receiver Disable Time from High	t _{RHZ}	C _L = 100pF, S2 closed		20	50	ns
Time to Shutdown	t _{SHDN}	(Note 1)	50	200	600	ns
Driver Enable from Shutdown to Output High	t _{DZH(SHDN)}	Fig 4 and 6, C _L = 15pF, S2 closed			6000	ns
Driver Enable from Shutdown to Output Low	t _{DZL(SHDN)}	Fig 4 and 6, C _L = 15pF, S1 closed			6000	ns
Receiver Enable from Shutdown to Output High	t _{RZH(SHDN)}	Fig 2 and 8, C _L = 100pF, S2 closed			3500	ns
Receiver Enable from Shutdown to Output Low	t _{RZL(SHDN)}	Fig 2 and 8, C _L = 100pF, S1 closed			3500	ns

Note 1: The device is put into shutdown by bringing \overline{RE} high and DE low. If the enable inputs are in this state for less than 50ns, The device is guaranteed not to enter shutdown. If the enable inputs are in this state for at least 600ns, the device is guaranteed to have entered shutdown.

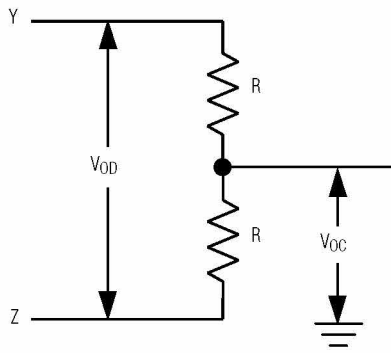

Fig 1. Driver DC Test Load

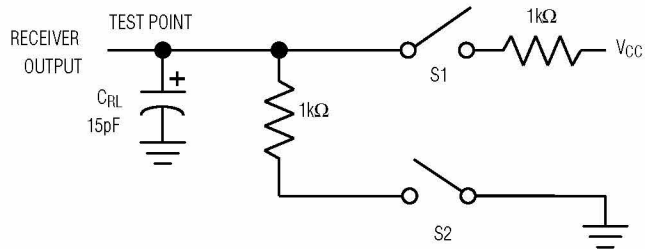

Fig 2. Receiver Enable/Disable Timing Test Load

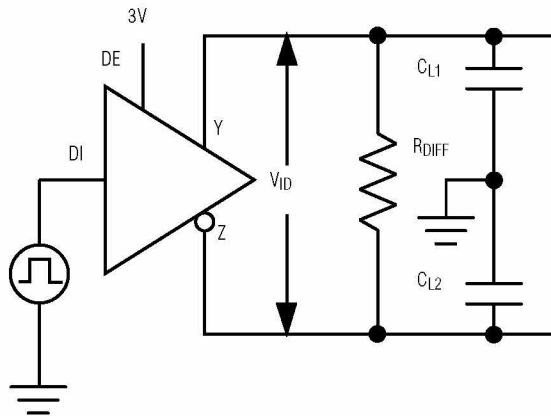

Fig 3. Driver Timing Test Circuit

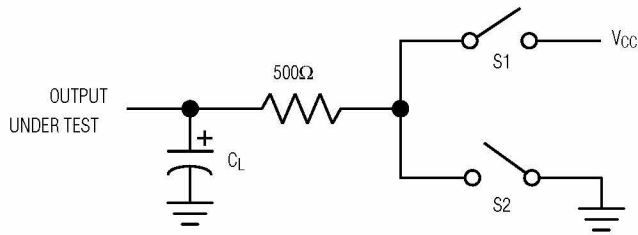

Fig 4 Driver Enable/Disable Timing Test Load

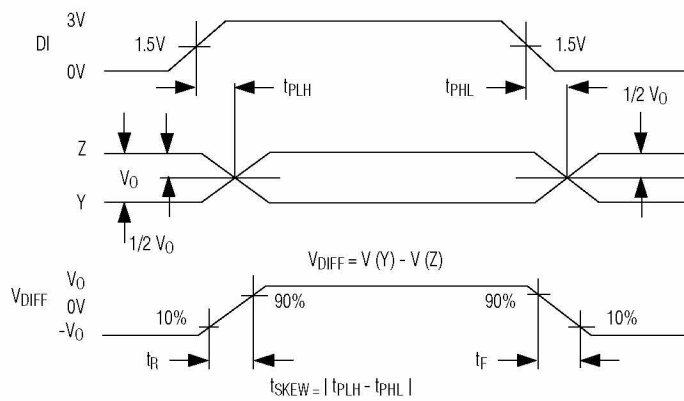

Fig 5. Driver Propagation Delays

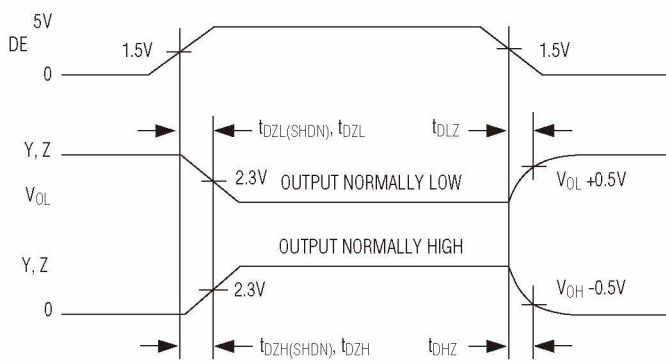

Fig 6. Driver Enable and Disable Times

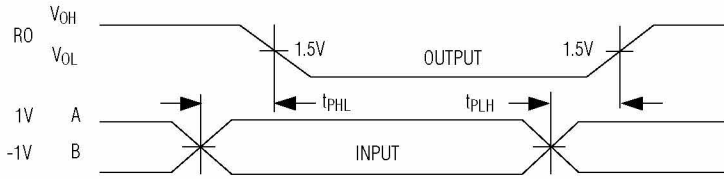

Fig 7. Receiver Propagation Delays

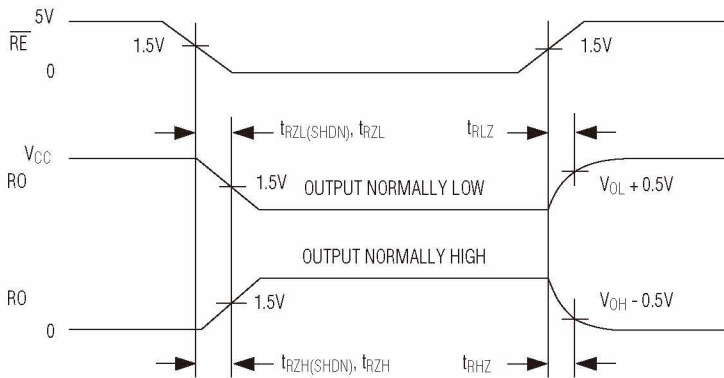

Fig 8. Receiver Enable and Disable Times

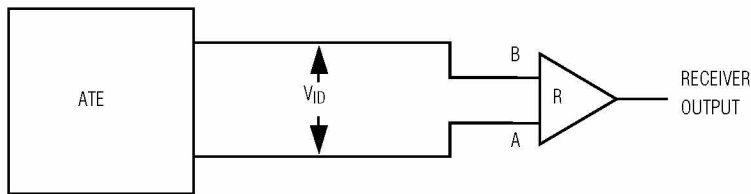

Fig 9. Receiver Propagation Delay Test Circuit

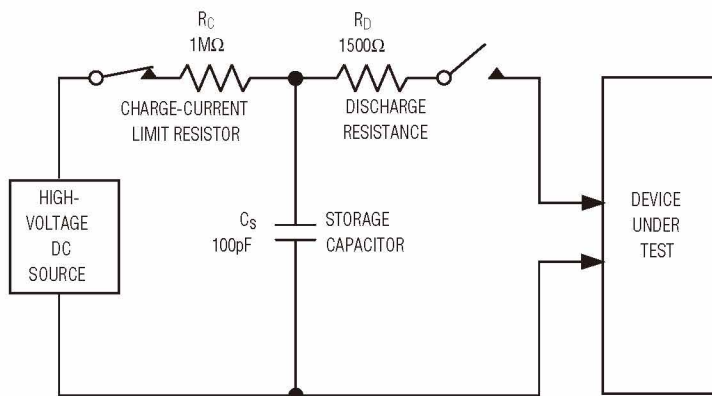
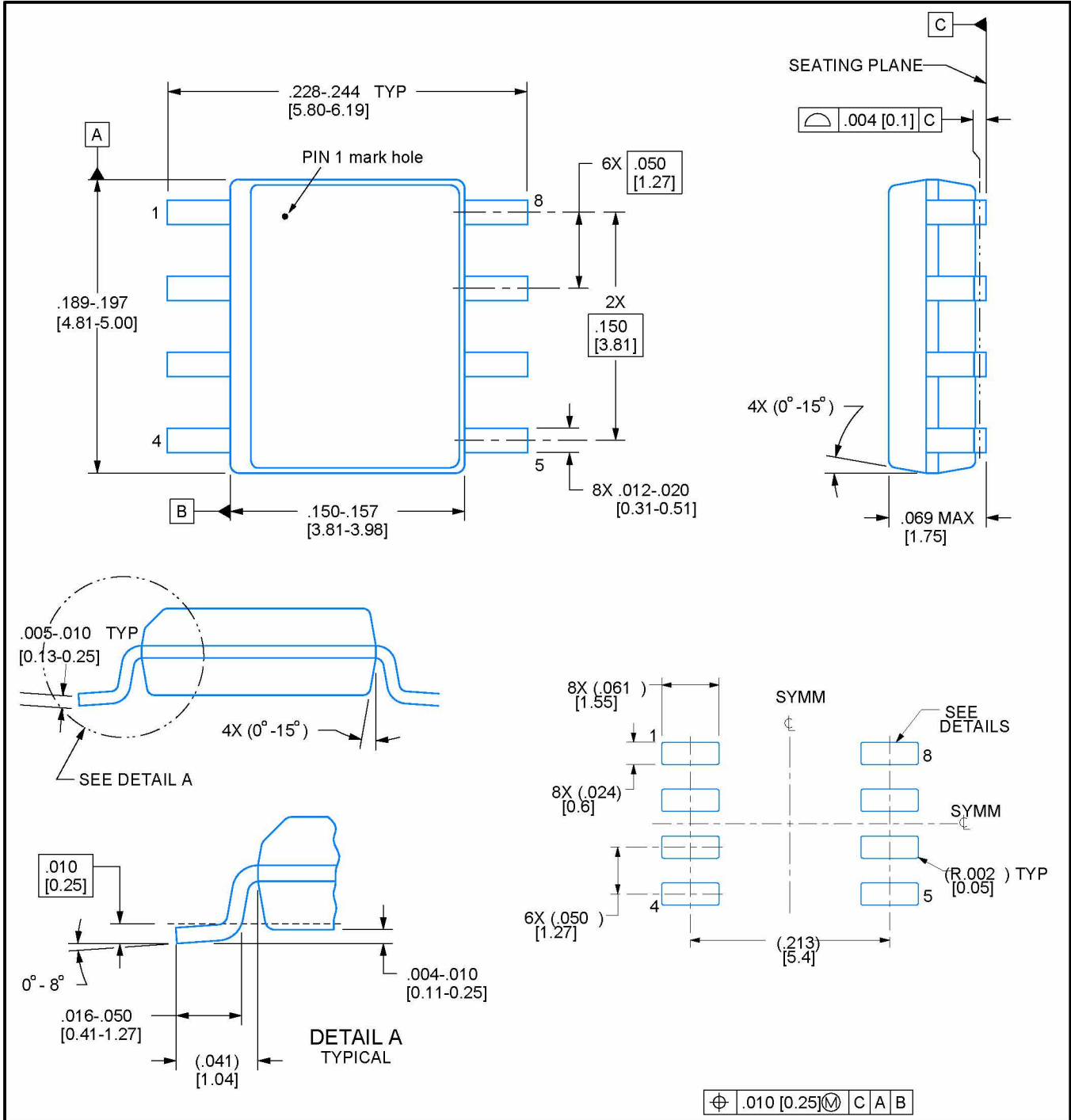

Fig 10. Human Body ESD Test Model

PACKAGE OUTLINE SOIC - 8, 1.75 mm max height



NOTES: Linear dimensions are in inches [millimeters]. This dimension does not include mold flash, protrusions, or gate burrs. Mold flash, protrusions, or gate burrs shall not exceed $.006$ [0.15] per side.