

3.0 A, 15 V, Step-Down Switching Regulator

General Description

The TK2576 series of regulators are monolithic integrated circuits ideally suited for easy and convenient design of a step-down switching regulator (buck converter). All circuits of this series are capable of driving a 3.0 A load with excellent line and load regulation. These devices are available in fixed output voltages of 3.3 V, 5.0 V, 12 V, 15 V, and an adjustable output version.

These regulators were designed to minimize the number of external components to simplify the power supply design. Standard series of inductors optimized for use with the TK2576 are offered by several different inductor manufacturers. Since the TK2576 converter is a switch-mode power supply, its efficiency is significantly higher in comparison with popular three-terminal linear regulators, especially with higher input voltages.

In many cases, the power dissipated is so low that no heatsink is required or its size could be reduced dramatically.

A standard series of inductors optimized for use with the TK2576 are available from several different manufacturers. This feature greatly simplifies the design of switch-mode power supplies. The TK2576 features include a guaranteed $\pm 4\%$ tolerance on output voltage within specified input voltages and output load conditions, and $\pm 10\%$ on the oscillator frequency ($\pm 2\%$ over 0°C to 125°C). External shutdown is included, featuring $80\ \mu\text{A}$ (typical) standby current. The output switch includes cycle-by-cycle current limiting, as well as thermal shutdown for full protection under fault conditions.

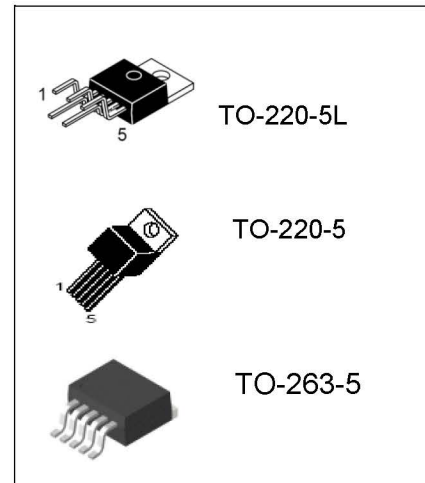

Features

- 3.3 V, 5.0 V, 12 V, 15 V, and Adjustable Output Versions
- Adjustable Version Output Voltage Range, 1.23 to 37 V $\pm 4\%$
- Maximum Over Line and Load Conditions
- Guaranteed 3.0 A Output Current
- Wide Input Voltage Range
- Requires Only 4 External Components
- 52 kHz Fixed Frequency Internal Oscillator
- TTL Shutdown Capability, Low Power Standby Mode
- High Efficiency
- Uses Readily Available Standard Inductors
- Thermal Shutdown and Current Limit Protection

Applications

- Simple High-Efficiency Step-Down (Buck) Regulator
- Efficient Pre-Regulator for Linear Regulators
- On-Card Switching Regulators
- Positive to Negative Converter (Buck-Boost)
- Negative Step-Up Converters
- Power Supply for Battery Chargers

ORDERING INFORMATION

Part Number	Package	Packing	Temperature (TA)	Package Qty
TK2576T-3.3	TO-220-5	Tube	-40°C ~ 125°C	1000
TK2576T-5.0	TO-220-5	Tube	-40°C ~ 125°C	1000
TK2576T-12	TO-220-5	Tube	-40°C ~ 125°C	1000
TK2576T-15	TO-220-5	Tube	-40°C ~ 125°C	1000
TK2576T-ADJ	TO-220-5	Tube	-40°C ~ 125°C	1000
TK2576TL-3.3	TO-220-5L	Tube	-40°C ~ 125°C	1000
TK2576TL-5.0	TO-220-5L	Tube	-40°C ~ 125°C	1000
TK2576TL-12	TO-220-5L	Tube	-40°C ~ 125°C	1000
TK2576TL-15	TO-220-5L	Tube	-40°C ~ 125°C	1000
TK2576TL-ADJ	TO-220-5L	Tube	-40°C ~ 125°C	1000
TK2576SX-3.3	TO-263-5	Reel	-40°C ~ 125°C	500
TK2576SX-5.0	TO-263-5	Reel	-40°C ~ 125°C	500
TK2576SX-12	TO-263-5	Reel	-40°C ~ 125°C	500
TK2576SX-15	TO-263-5	Reel	-40°C ~ 125°C	500
TK2576SX-ADJ	TO-263-5	Reel	-40°C ~ 125°C	500

Pin Description

PIN		I/O ⁽¹⁾	DESCRIPTION
NO.	NAME		
1	V _{IN}	I	Supply input pin to collector pin of high-side transistor. Connect to power supply and input bypass capacitors C _{IN} . Path from V _{IN} pin to high frequency bypass C _{IN} and GND must be as short as possible.
2	OUTPUT	O	Emitter pin of the power transistor. This is a switching node. Attached this pin to an inductor and the cathode of the external diode.
3	GROUND	—	Ground pin. Path to C _{IN} must be as short as possible.
4	FEEDBACK	I	Feedback sense input pin. Connect to the midpoint of feedback divider to set V _{OUT} for ADJ version or connect this pin directly to the output capacitor for a fixed output version.
5	ON/OFF	I	Enable input to the voltage regulator. High = OFF and low = ON. Connect to GND to enable the voltage regulator. Do not leave this pin float.
—	TAB	—	Connected to GND. Attached to heatsink for thermal relief for TO-220 package or put a copper plane connected to this pin as a thermal relief for DDPACK package.

(1) I = INPUT, O = OUTPUT

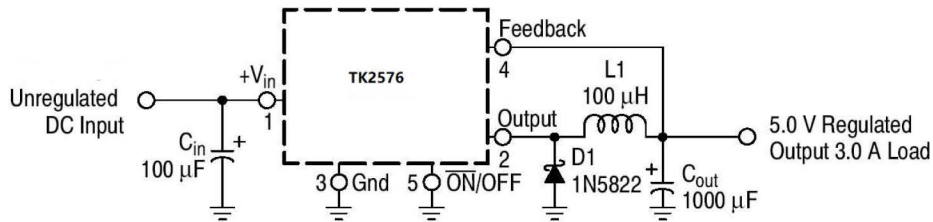
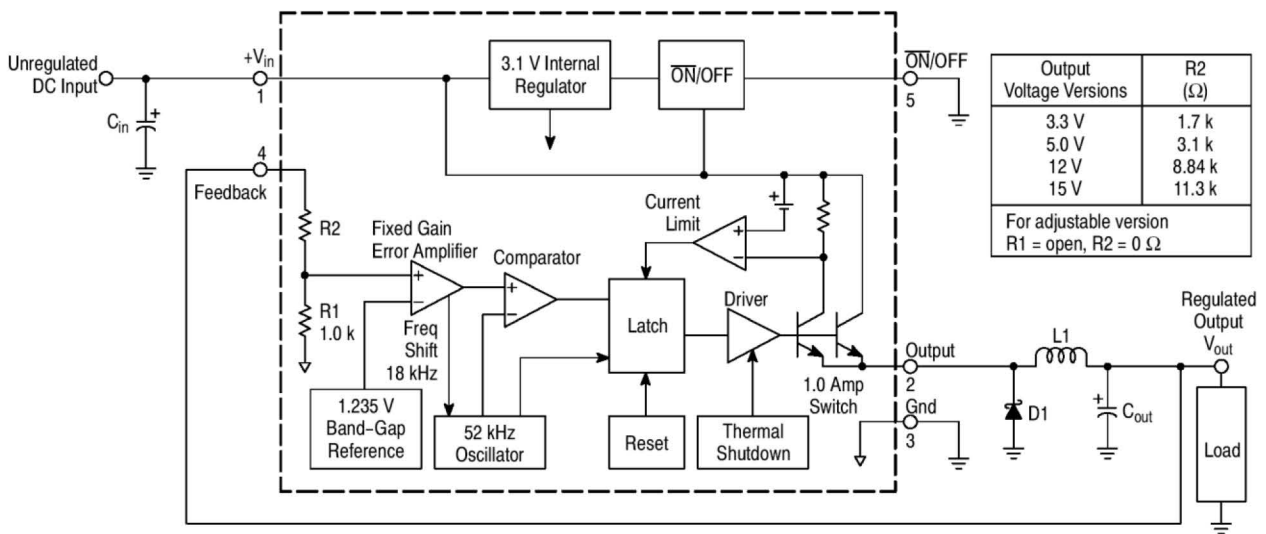
Typical Application (Fixed Output Voltage Versions)

Figure 1.
Representative Block Diagram and Typical Application

This device contains 162 active transistors.

Figure 2.
ABSOLUTE MAXIMUM RATINGS

(Absolute Maximum Ratings indicate limits beyond which damage to the device may occur.)

Rating	Symbol	Value	Unit
Maximum Supply Voltage	V _{in}	45	V
ON/OFF Pin Input Voltage	—	-0.3 V ≤ V ≤ +V _{in}	V
Output Voltage to Ground (Steady-State)	—	-1.0	V
Power Dissipation	P _D	Internally Limited	W
TO-220, 5-Lead	R _{θJA}	65	°C/W
Thermal Resistance, Junction-to-Ambient	R _{θJC}	5.0	°C/W
Thermal Resistance, Junction-to-Case	P _D	Internally Limited	W
TO-263, 5-Lead (D2PAK)	R _{θJA}	70	°C/W
Thermal Resistance, Junction-to-Ambient	R _{θJC}	5.0	°C/W
Thermal Resistance, Junction-to-Case	T _{stg}	-65 to +150	°C
Storage Temperature Range	—	2.0	kV
Minimum ESD Rating (Human Body Model: C = 100 pF, R = 1.5 kΩ)	—	260	°C
Lead Temperature (Soldering, 10 seconds)	T _J	150	°C
Maximum Junction Temperature	—	—	—

* Stresses beyond those listed under "absolute maximum ratings" may cause permanent damage to the device. These are stress ratings only and functional operation of the device at these or any other conditions beyond those indicated under "recommended operating conditions" is not implied. Exposure to absolute-maximum-rated conditions for extended periods may affect device reliability.

OPERATING RATINGS

(Operating Ratings indicate conditions for which the device is intended to be functional, but do not guarantee specific performance limits. For guaranteed specifications and test conditions, see the Electrical Characteristics.)

Rating	Symbol	Value	Unit
Operating Junction Temperature Range	T_J	-40 to +125	°C
Supply Voltage	V_{in}	40	V

SYSTEM PARAMETERS [Note 1]

ELECTRICAL CHARACTERISTICS

(Unless otherwise specified, $V_{in} = 12\text{ V}$ for the 3.3 V, 5.0 V, and Adjustable version, $V_{in} = 25\text{ V}$ for the 12 V version, and $V_{in} = 30\text{ V}$ for the 15 V version. $I_{Load} = 500\text{ mA}$, $T_J = 25^\circ\text{C}$, for min/max values T_J is the operating junction temperature range that applies [Note 2], unless otherwise noted.)

Characteristics	Symbol	Min	Max	Unit
TK2576-3.3 [Note 1] Test Circuit Figure 3)				
Output Voltage	V_{out}	3.234	3.366	V
Output Voltage (6.0 V ≤ V_{in} ≤ 40 V, 0.5 A ≤ I_{Load} ≤ 3.0 A) $T_J = 25^\circ\text{C}$ $T_J = -40\text{ to }+125^\circ\text{C}$	V_{out}	3.168 3.135	3.432 3.465	V
Efficiency ($V_{in} = 12\text{ V}$, $I_{Load} = 3.0\text{ A}$)	η	65	-	%
TK2576-5 [Note 1]				
Output Voltage	V_{out}	4.9	5.1	V
Output Voltage (8.0 V ≤ V_{in} ≤ 40 V, 0.5 A ≤ I_{Load} ≤ 3.0 A) $T_J = 25^\circ\text{C}$ $T_J = -40\text{ to }+125^\circ\text{C}$	V_{out}	4.8 4.75	5.2 5.25	V
Efficiency ($V_{in} = 12\text{ V}$, $I_{Load} = 3.0\text{ A}$)	η	67	-	%
TK2576-12 [Note 1]				
Output Voltage	V_{out}	11.76	12.24	V
Output Voltage (15.0 V ≤ V_{in} ≤ 40 V, 0.5 A ≤ I_{Load} ≤ 3.0 A) $T_J = 25^\circ\text{C}$ $T_J = -40\text{ to }+125^\circ\text{C}$	V_{out}	11.52 11.4	12.48 12.6	V
Efficiency ($V_{in} = 12\text{ V}$, $I_{Load} = 3.0\text{ A}$)	η	78	-	%
TK2576-15 [Note 1]				
Output Voltage	V_{out}	14.7	15.3	V
Output Voltage (18 V ≤ V_{in} ≤ 40 V, 0.5 A ≤ I_{Load} ≤ 3.0 A) $T_J = 25^\circ\text{C}$ $T_J = -40\text{ to }+125^\circ\text{C}$	V_{out}	14.4 14.25	15.6 15.75	V
Efficiency ($V_{in} = 12\text{ V}$, $I_{Load} = 3.0\text{ A}$)	η	78	-	%
TK2576 ADJUSTABLE VERSION [Note 1]				
Feedback Voltage ($V_{in} = 12\text{ V}$, $I_{Load} = 0.5\text{ A}$, $V_{out} = 5.0\text{ V}$, $T_J = 25^\circ\text{C}$)	V_{out}	1.217	1.243	V
Feedback Voltage (8.0 V ≤ V_{in} ≤ 40 V, 0.5 A ≤ I_{Load} ≤ 3.0 A, $V_{out} = 5.0\text{ V}$) $T_J = 25^\circ\text{C}$ $T_J = -40\text{ to }+125^\circ\text{C}$	V_{out}	1.193 1.18	1.267 1.28	V
Efficiency ($V_{in} = 12\text{ V}$, $I_{Load} = 3.0\text{ A}$, $V_{out} = 5.0\text{ V}$)	η	67	-	%

1. External components such as the catch diode, inductor, input and output capacitors can affect switching regulator system performance. When the TK2576 is used as shown in the test circuit, system performance will be as shown in system parameters section .

2. Tested junction temperature range for the TK2576: $T_{low} = -40^\circ\text{C}$ $T_{high} = +125^\circ\text{C}$

ELECTRICAL CHARACTERISTICS

(Unless otherwise specified, $V_{in} = 12\text{ V}$ for the 3.3 V, 5.0 V, and Adjustable version, $V_{in} = 25\text{ V}$

for the 12 V version, and $V_{in} = 30\text{ V}$ for the 15 V version. $I_{Load} = 500\text{ mA}$, $T_J = 25^\circ\text{C}$, for min/max values T_J is the operating junction temperature range that applies [Note 2], unless otherwise noted.)

Characteristics	Symbol	Min	Max	Unit
ALL OUTPUT VOLTAGE VERSIONS				
Feedback Bias Current ($V_{out} = 5.0\text{ V}$ [Adjustable Version Only]) $T_J = 25^\circ\text{C}$ $T_J = -40\text{ to }+125^\circ\text{C}$	I_b	– –	100 500	nA
Oscillator Frequency [Note 3] $T_J = 25^\circ\text{C}$ $T_J = -40\text{ to }+125^\circ\text{C}$	f_{osc}	– 42	– 63	kHz
Saturation Voltage ($I_{out} = 3.0\text{ A}$ [Note 4]) $T_J = 25^\circ\text{C}$ $T_J = -40\text{ to }+125^\circ\text{C}$	V_{sat}	– –	1.8 2.0	V
Max Duty Cycle (“on”) [Note 5]	D_C	93	–	%
Current Limit (Peak Current [Notes 3 and 4]) $T_J = 25^\circ\text{C}$ $T_J = -40\text{ to }+125^\circ\text{C}$	I_{CL}	4.2 3.5	6.9 7.5	A
Output Leakage Current [Notes 6 and 7], $T_J = 25^\circ\text{C}$ Output = 0 V Output = –1.0 V	I_L	– –	2.0 30	mA
Quiescent Current [Note 6] $T_J = 25^\circ\text{C}$ $T_J = -40\text{ to }+125^\circ\text{C}$	I_Q	– –	10 11	mA
Standby Quiescent Current (ON/OFF Pin = 5.0 V (“off”)) $T_J = 25^\circ\text{C}$	I_{stby}	–	200	uA
ON/OFF Pin Logic Input Level $V_{out} = 0\text{ V}$ $T_J = 25^\circ\text{C}$ $T_J = -40\text{ to }+125^\circ\text{C}$ $V_{out} = \text{Nominal Output Voltage}$ $T_J = 25^\circ\text{C}$ $T_J = -40\text{ to }+125^\circ\text{C}$	V_{IH} V_{IL}	2.2 2.4 – –	– – 1.0 0.8	V
ON/OFF Pin Input Current ON/OFF Pin = 5.0 V (“off”), $T_J = 25^\circ\text{C}$ ON/OFF Pin = 0 V (“on”), $T_J = 25^\circ\text{C}$	I_{IH} I_{IL}	– –	30 10	uA

3. The oscillator frequency reduces to approximately 18 kHz in the event of an output short or an overload which causes the regulated output voltage to drop approximately 40% from the nominal output voltage. This self protection feature lowers the average dissipation of the IC by lowering the minimum duty cycle from 5% down to approximately 2%.

4. Output (Pin 2) sourcing current. No diode, inductor or capacitor connected to output pin.

5. Feedback (Pin 4) removed from output and connected to 0 V.

6. Feedback (Pin 4) removed from output and connected to +12 V for the Adjustable, 3.3 V, and 5.0 V versions, and +25 V for the 12 V and 15 V versions, to force the output transistor “off”.

7. $V_{in} = 40\text{ V}$.

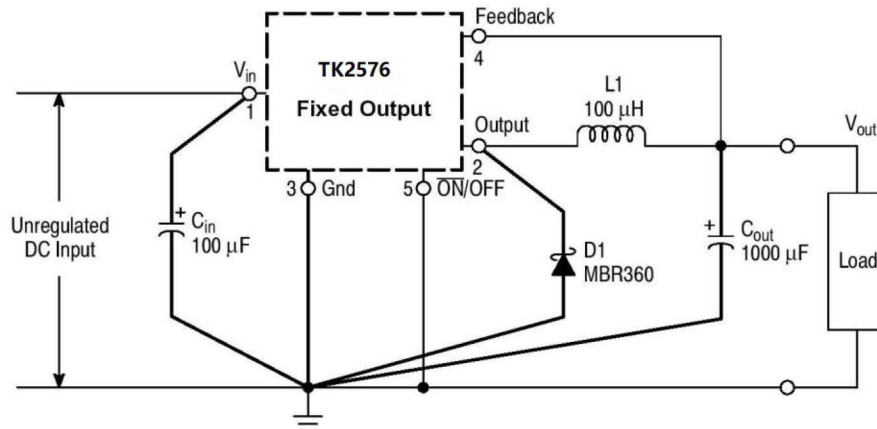
Fixed Output Voltage Versions

Figure 3.

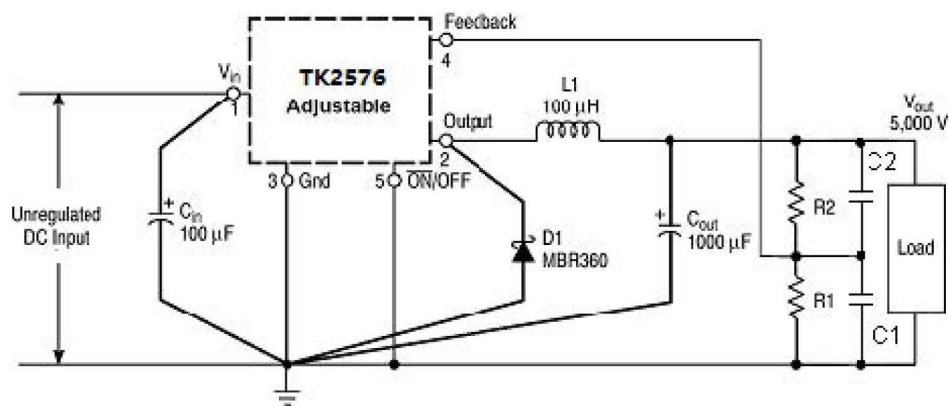
Cin – 100 mF, 75 V, Aluminium Electrolytic
 Cout – 1000 mF, 25 V, Aluminium Electrolytic
 D1 – Schottky, MBR360
 L1 – 100 mH, Pulse Eng. PE-92108
 R1 – 2.0 k, 0.1%
 R2 – 6.12 k, 0.1%

Adjustable Output Voltage Versions

Figure 4.

$$V_{out} = V_{ref} \left(1.0 + \frac{R_2}{R_1} \right), \quad R_2 = R_1 \left(\frac{V_{out}}{V_{ref}} - 1.0 \right)$$

Where Vref = 1.23 V, R1 between 1.0 k and 5.0 k

C1 = 10 nF
 C2 = 1 nF

Application Information

INVERTING REGULATOR

Figure 5 shows a TK2576-12 in a buck-boost configuration to generate a negative 12V output from a positive input voltage. This circuit bootstraps the regulator's ground pin to the negative output voltage, then by grounding the feedback pin, the regulator senses the inverted output voltage and regulates it to -12V.

For an input voltage of 12V or more, the maximum available output current in this configuration is approximately 700 mA. At lighter loads, the minimum input voltage required drops to approximately 4.7V.

The switch currents in this buck-boost configuration are higher than in the standard buck-mode design, thus lowering the available output current. Also, the start-up input current of the buck-boost converter is higher than the standard buck-mode regulator, and this may overload an input power source with a current limit less than 5A. Using a delayed turn-on or an undervoltage lockout circuit (described in the next section) would allow the input voltage to rise to a high enough level before the switcher would be allowed to turn on.

Because of the structural differences between the buck and the buck-boost regulator topologies, the buck regulator design procedure section can not be used to select the inductor or the output capacitor. The recommended range of inductor values for the buck-boost design is between 68 μH and 220 μH , and the output capacitor values must be larger than what is normally required for buck designs. Low input voltages or high output currents require a large value output capacitor (in the thousands of micro Farads).

The peak inductor current, which is the same as the peak switch current, can be calculated from the following formula:

$$I_p \approx \frac{I_{\text{LOAD}}(V_{\text{IN}} + |V_{\text{O}}|)}{V_{\text{IN}}} + \frac{V_{\text{IN}}|V_{\text{O}}|}{V_{\text{IN}} + |V_{\text{O}}|} \times \frac{1}{2L_1 f_{\text{osc}}}$$

Where $f_{\text{osc}} = 52 \text{ kHz}$. Under normal continuous inductor current operating conditions, the minimum V_{IN} represents the worst case. Select an inductor that is rated for the peak current anticipated.

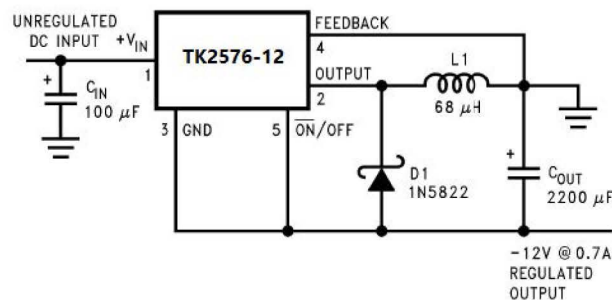
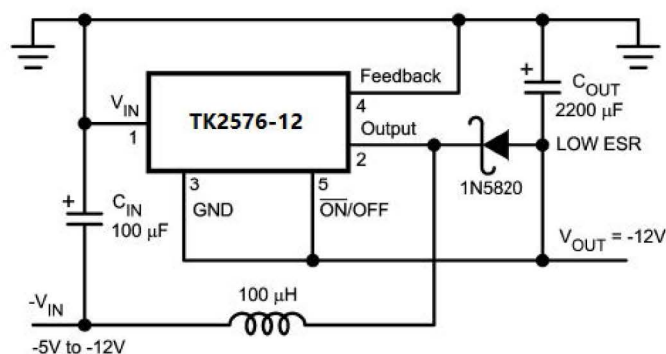

FIGURE 5. Inverting Buck-Boost Develops -12V

Also, the maximum voltage appearing across the regulator is the absolute sum of the input and output voltage. For a -12V output, the maximum input voltage for the TK2576 is +28V.

NEGATIVE BOOST REGULATOR

Another variation on the buck-boost topology is the negative boost configuration. The circuit in Figure 6 accepts an input voltage ranging from -5V to -12V and provides a regulated -12V output. Input voltages greater than -12V will cause the output to rise above -12V, but will not damage the regulator.



Typical Load Current
 400 mA for $V_{\text{IN}} = -5.2\text{V}$
 750 mA for $V_{\text{IN}} = -7\text{V}$

Note: Heat sink may be required.

FIGURE 6. Negative Boost

Because of the boosting function of this type of regulator, the switch current is relatively high, especially at low input voltages.

Output load current limitations are a result of the maximum current rating of the switch. Also, boost regulators can not provide current limiting load protection in the event of a shorted load, so some other means (such as a fuse) may be necessary.

UNDERVOLTAGE LOCKOUT

In some applications it is desirable to keep the regulator off until the input voltage reaches a certain threshold. An undervoltage lockout circuit which accomplishes this task is shown in *Figure 7* while *Figure 8* shows the same circuit applied to a buck-boost configuration. These circuits keep the regulator off until the input voltage reaches a predetermined level.

$$V_{TH} = V_{Z1} + 2V_{BE}(Q1)$$

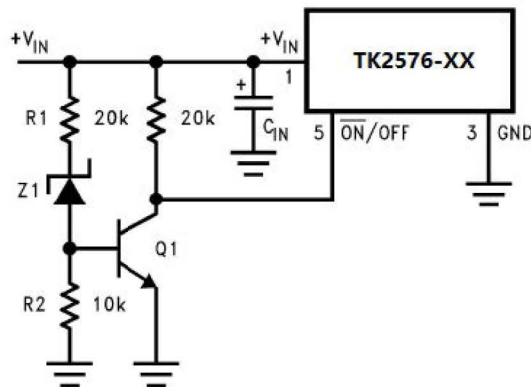

Note: Complete circuit not shown.

FIGURE 7. Undervoltage Lockout for Buck Circuit

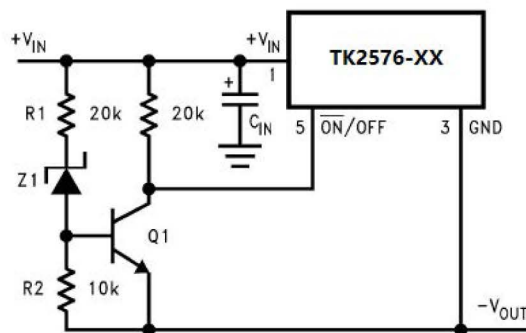

Note: Complete circuit not shown (see *Figure 10*).

FIGURE 8. Undervoltage Lockout for Buck-Boost Circuit

DELAYED STARTUP

The ON /OFF pin can be used to provide a delayed startup feature as shown in *Figure 9*. With an input voltage of 20V and for the part values shown, the circuit provides approximately 10 ms of delay time before the circuit begins switching.

Increasing the RC time constant can provide longer delay times. But excessively large RC time constants can cause problems with input voltages that are high in 60 Hz or 120 Hz ripple, by coupling the ripple into the ON /OFF pin.

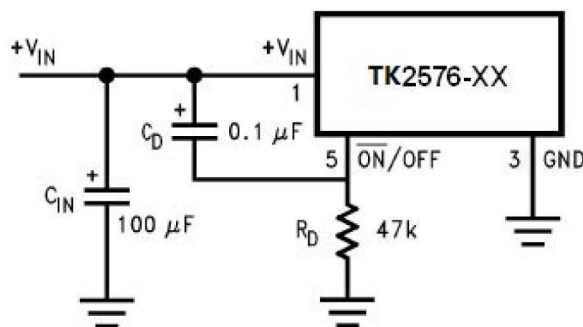

Note: Complete circuit not shown.

FIGURE 9. Delayed Startup

ADJUSTABLE OUTPUT, LOW-RIPPLE POWER SUPPLY

A 3A power supply that features an adjustable output voltage is shown in *Figure 10*. An additional L-C filter that reduces the output ripple by a factor of 10 or more is included in this circuit.

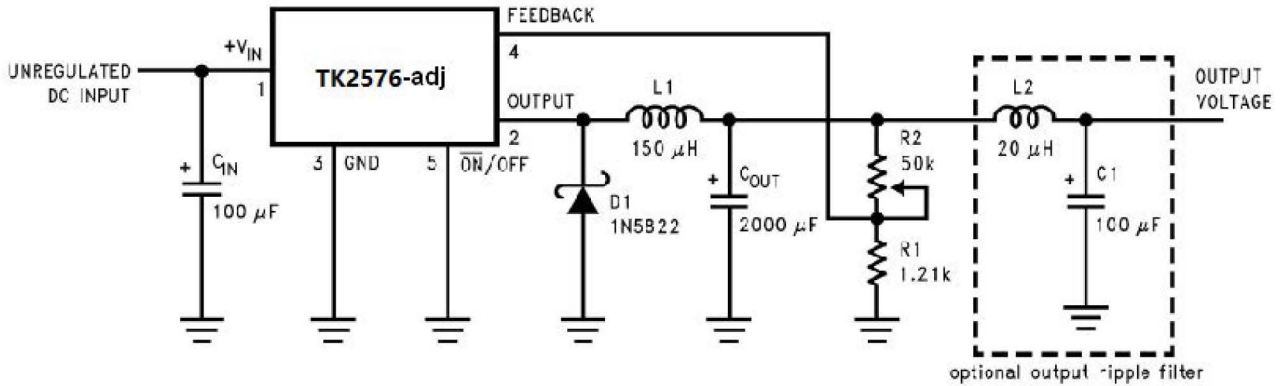

FIGURE 10. Adjustable 3A Power Supply with Low Output Ripple

Definition of Terms
BUCK REGULATOR

A switching regulator topology in which a higher voltage is converted to a lower voltage. Also known as a step-down switching regulator.

BUCK-BOOST REGULATOR

A switching regulator topology in which a positive voltage is converted to a negative voltage without a transformer.

DUTY CYCLE (D)

Ratio of the output switch's on-time to the oscillator period.

$$\text{for buck regulator} \quad D = \frac{t_{\text{ON}}}{T} = \frac{V_{\text{OUT}}}{V_{\text{IN}}}$$

$$\text{for buck-boost regulator} \quad D = \frac{t_{\text{ON}}}{T} = \frac{|V_{\text{O}}|}{|V_{\text{O}}| + V_{\text{IN}}}$$

CATCH DIODE OR CURRENT STEERING DIODE

The diode which provides a return path for the load current when the TK2576 switch is OFF. **EFFICIENCY (η)**

The proportion of input power actually delivered to the load.

$$\eta = \frac{P_{\text{OUT}}}{P_{\text{IN}}} = \frac{P_{\text{OUT}}}{P_{\text{OUT}} + P_{\text{LOSS}}}$$

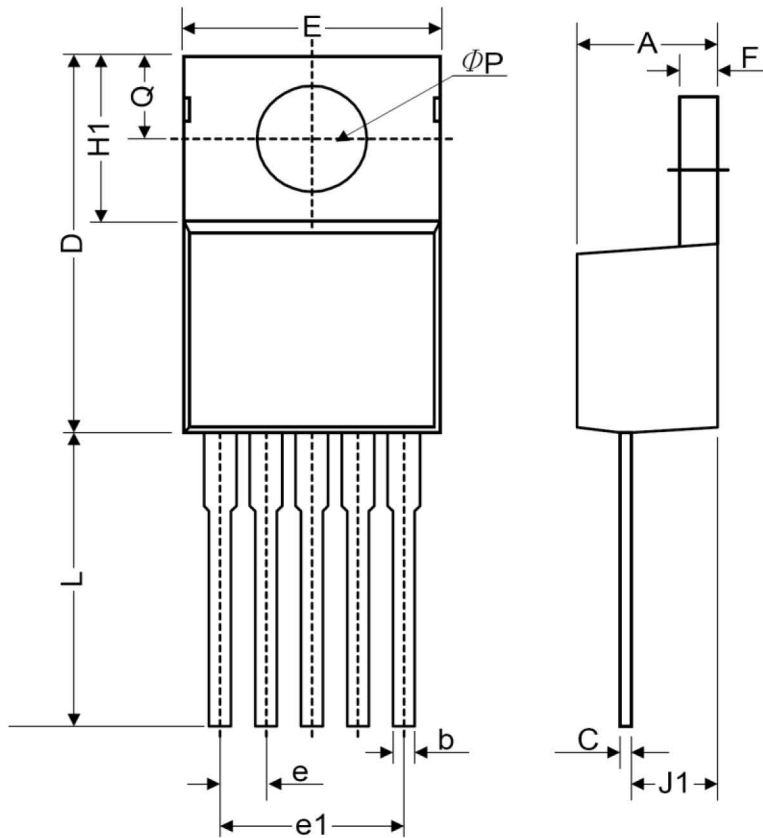
TO-220-5

Symbol	Dimensions In Millimeters			Dimensions In Inches		
	Min.	Nom.	Max.	Min.	Nom.	Max.
A	4.07	4.45	4.82	0.160	0.175	0.190
b	0.76	0.89	1.02	0.030	0.035	0.040
C	0.36	0.50	0.64	0.014	0.020	0.025
D	14.22	14.86	15.50	0.560	0.585	0.610
E	9.78	10.16	10.54	0.385	0.400	0.415
e	1.57	1.71	1.85	0.062	0.067	0.073
e1	6.68	6.81	6.93	0.263	0.268	0.273
F	1.14	1.27	1.40	0.045	0.050	0.055
H1	5.46	6.16	6.86	0.215	0.243	0.270
J1	2.29	2.74	3.18	0.090	0.108	0.125
L	13.21	13.97	14.73	0.520	0.550	0.580
ϕp	3.68	3.81	3.94	0.145	0.150	0.155
Q	2.54	2.73	2.92	0.100	0.107	0.115

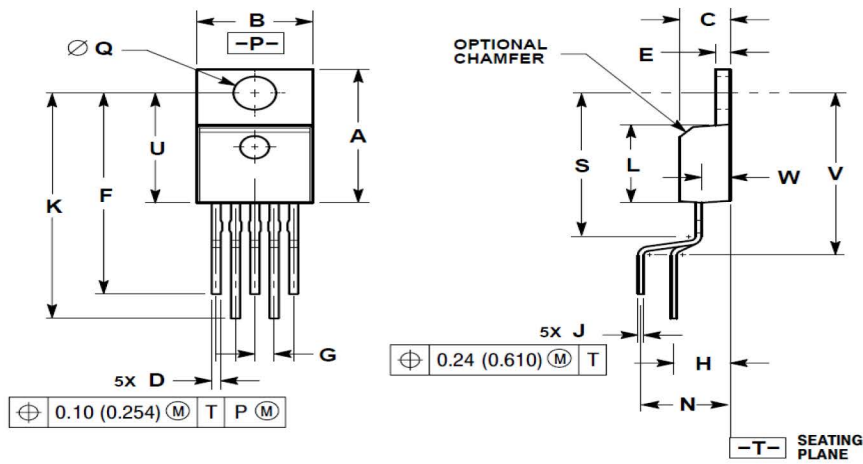
TO-220-5L
TO-220
TV SUFFIX
CASE 314B-05
ISSUE J

구분	IK TO 220SD 5L		
	min	avg	max
A	14.529		15.570
B	9.906		10.541
C	4.318		4.572
D	0.635		0.965
E	1.219		1.397
F	21.590		23.749
G	1.702BSC		
H	4.216BSC		
J	0.381		0.635
K	22.860		27.940
L	8.128		9.271
N	8.128BSC		
$\varnothing Q$	3.556		3.886
S			15.748
U	11.888		12.827
V			18.669
W	2.286		2.794

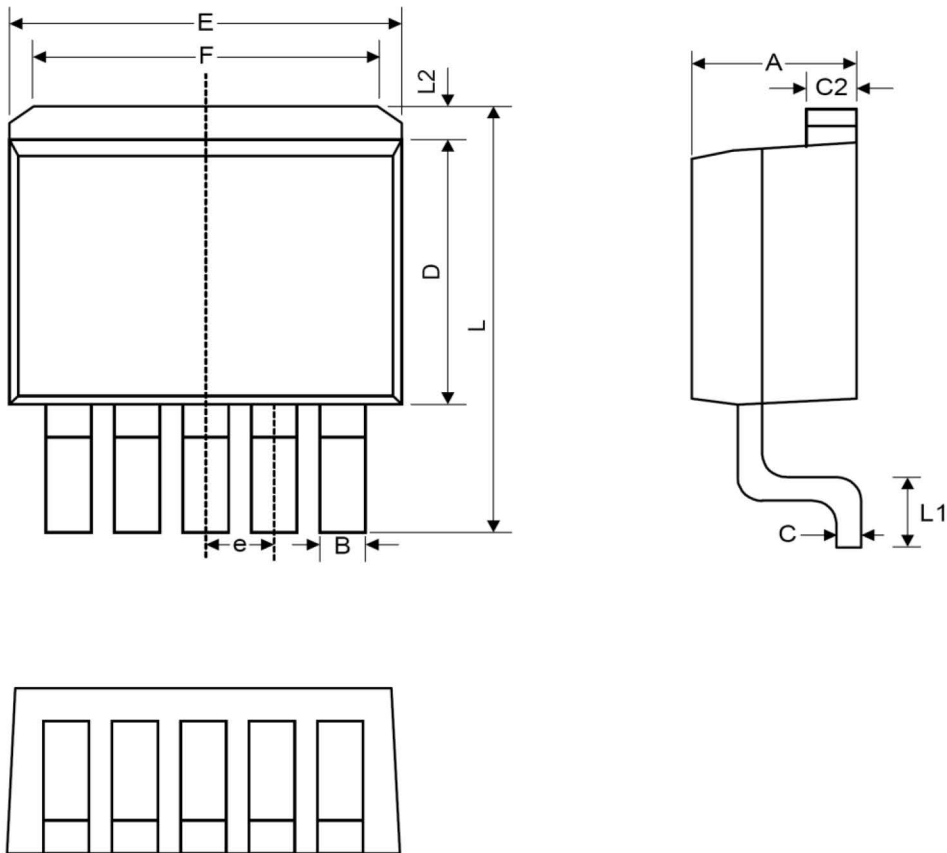
TO-263-5

Symbol	Dimensions In Millimeters			Dimensions In Inches		
	Min.	Nom.	Max.	Min.	Nom.	Max.
A	4.07	4.46	4.85	0.160	0.176	0.191
B	0.66	0.84	1.02	0.026	0.033	0.040
C	0.36	0.50	0.64	0.014	0.020	0.025
C2	1.14	1.27	1.40	0.045	0.050	0.055
D	8.65	9.15	9.65	0.341	0.360	0.380
E	9.78	10.16	10.54	0.385	0.400	0.415
e	1.57	1.71	1.85	0.062	0.068	0.073
F	6.60	6.86	7.11	0.260	0.270	0.280
L	14.61	15.24	15.88	0.575	0.600	0.625
L1	2.29	2.54	2.79	0.090	0.100	0.110
L2	-	-	2.92	-	-	0.115