

1.5A 3-Terminal Adjustable Regulator

Description

The LM317 is adjustable 3-terminal positive voltage regulator capable of supplying in excess of 1.5 A over an output voltage range of 1.2 V to 37 V. These voltage regulator is exceptionally easy to use and require only two external resistors to set the output voltage. Further, it employ internal current limiting, thermal shutdown and safe area compensation, making them essentially blow-out proof.

The LM317 serve a wide variety of applications to make a programmable output regulator, or by connecting a fixed resistor between the adjustment and output, the LM317 series can be used as a precision current regulator.

Futures

- Output Current in Excess of 1.5 Ampere
- Output Adjustable between 1.2 V and 37 V
- Internal Thermal Overload Protection
- Internal Short - Circuit Current Limiting Constant with Temperature
- Output Transistor Safe-Area Compensation
- Floating Operation for High Voltage Applications
- Standard 3-lead Transistor Packages
- Eliminates Stocking Many Fixed
- Operating Temperature Range 0°C ~ 125°C; -40°C ~ 125°C

Ordering Information

Part Number	Package	Packing	Temperature(TA)	Package Qty
LM317KTTR	TO-263-3	Reel	0°C ~ 125°C	2000
LM317KCS	TO-220-3	Tube	0°C ~ 125°C	2000
LM317DCYR	SOT-223-4	Reel	0°C ~ 125°C	2500
LM317AEMP	SOT-223-4	Reel	-40°C ~ 125°C	2500
LM317AMDTX	TO-252-3	Reel	-40°C ~ 125°C	2500
LM317AT	TO-220-3	Tube	-40°C ~ 125°C	2000

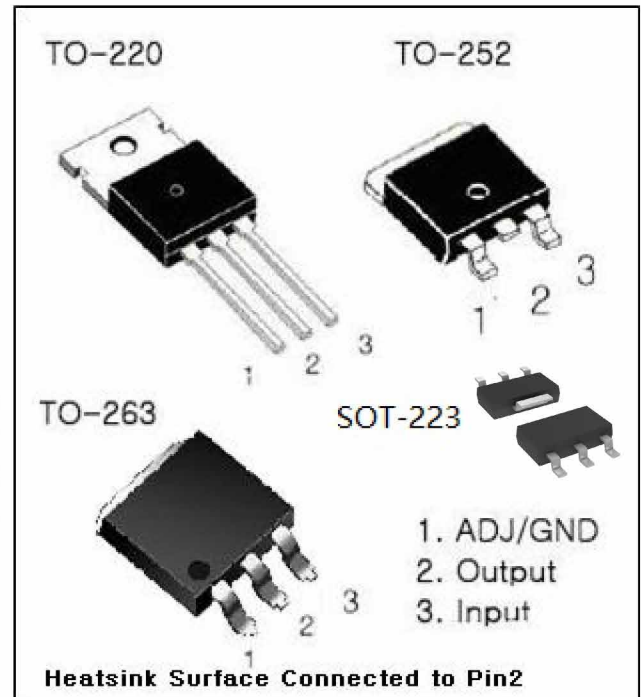

Standard application

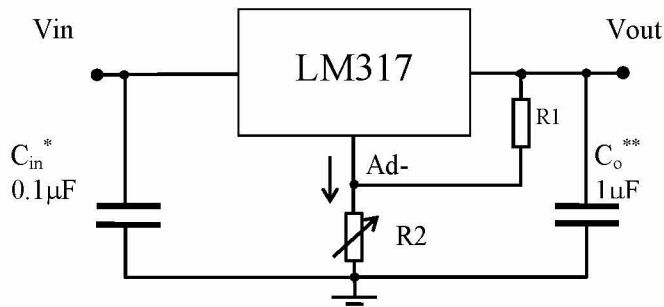

* = Cin is required if regulator is

located an appreciable distance from power supply filter.

** = Co is not needed for stability ; however, is does improve transient response.

$$V_{out} = 1.25V \left(1 + \frac{R2}{R1}\right) + I_{ADJ} * R2$$

Since IADJ is controlled to less then 100 µA, the error associated with this term is negligible in most applications.

Maximum ratings

Rating	Symbol	Value	Unit
Input - Output Voltage Differential	Vi - Vo	40	Vdc
Power Dissipation and Thermal Characteristics	PD	Internally Limited	
Operating Junction Temperature Rang	TJ	-40 to +150	°C
Storage Junction Temperature Rang	Tstg	-65 to +150	°C

* Stresses beyond those listed under "absolute maximum ratings" may cause permanent damage to the device. These are stress ratings only and functional operation of the device at these or any other conditions beyond those indicated under "recommended operating conditions" is not implied. Exposure to absolute-maximum-rated conditions for extended periods may affect device reliability.

Electrical characteristics

(Vi-Vo= 5.0V, Io = 0.5 A, Tj = Tlow to Thigh (see Note 1); Imax = 1.5 A and Pmax = 20 W unless otherwise noted)

Characteristic	Symbol	Min	Typ	Max	Unit
Line Regulation (TA=+25°C) 3.0V ≤ Vi - Vo ≤ 40 V	Regline	-	0.01	0.04	%/V
Load Regulation(TJ=+25°C) 10mA ≤ Io ≤ Imax, Vin ≤ 5V Vin ≥ 5 V	Regload	- -	5.0 0.1	25 0.5	mV %/Vo
Thermal Regulation (TA=+25°C) 20 ms Pulse	-	-	0.03	0.07	%/W
Adjustment Pin Current	IAdj	-	50	100	μA
Adjustment Pin Current Change 2.5 ≤ Vi - Vo ≤ 40 V 10mA ≤ IL ≤ Imax, PD ≤ Pmax	ΔIAdj	-	0.2	5.0	μA
Reference Voltage (Note 4) 3.0 ≤ Vi - Vo ≤ 40 V 10mA ≤ IL ≤ Imax, PD ≤ Pmax	Vref	1.2	1.25	1.3	V
Line Regulation (Note 3) 3.0 V ≤ Vi - Vo ≤ 40 V	Regline	-	0.02	0.07	%/V
Load Regulation (Note 3) 10mA ≤ Io ≤ Imax, Vin ≤ 5V Vin ≥ 5 V	Regload	- -	20 0.3	70 1.5	mV %/V
Temperature Stability (Tlow ≤ Tj ≤ Ttigh)	Ts	-	0.7	-	
Minimum Load Current to Maintain Regulation (Vi - Vo = 40 V)	ILmin	-	3.5	10	mA
Maximum Output Current Vi - Vo ≤ 15 V, P ≤ 20 W Vi - Vo = 40 V, P ≤ 20W, TA=+25°C	Imax	1.5 0.15	2.2 0.4	- -	A
RMS Nose, % of Vo TA=+25°C, 10 Hz ≤ f ≤ 10 kHz	N	-	0.003	-	%/Vo
Ripple Rejection, Vo = 10 V, f = 120 Hz (Note 5) Without Cadj Cadj = 10 μF	RR	- 66	65 80	- -	dB
Long-Term Stability, Tj = Thigh (Note 6) TA=+25°C for Endpoint Measurements	S	-	0.3	1.0	%/1.0 k Hrs.
Thermal Resistance Junction to Case	RθJC	-	5.0	-	°C/W

Notes: (1) Tlow = -40 °C, Thigh = +125 °C

(2) Imax = 0.5 A, Pmax

(3) Load and line regulation are specified at constant junction temperature. Changes in Vo due to heating effects must be taken into account separately. Pulse testing with low duty cycle is used.

(4) Selected devices with tightened tolerance reference voltage available.

(5) Cadj, when used, connected between the adjustment pin and ground.

(6) Since Long - Term Stability cannot be measured on each device before shipment, this specification is an engineering estimate of average stability from lot to lot.

TO-220AB PKG OUTLINE DIMENSIONS

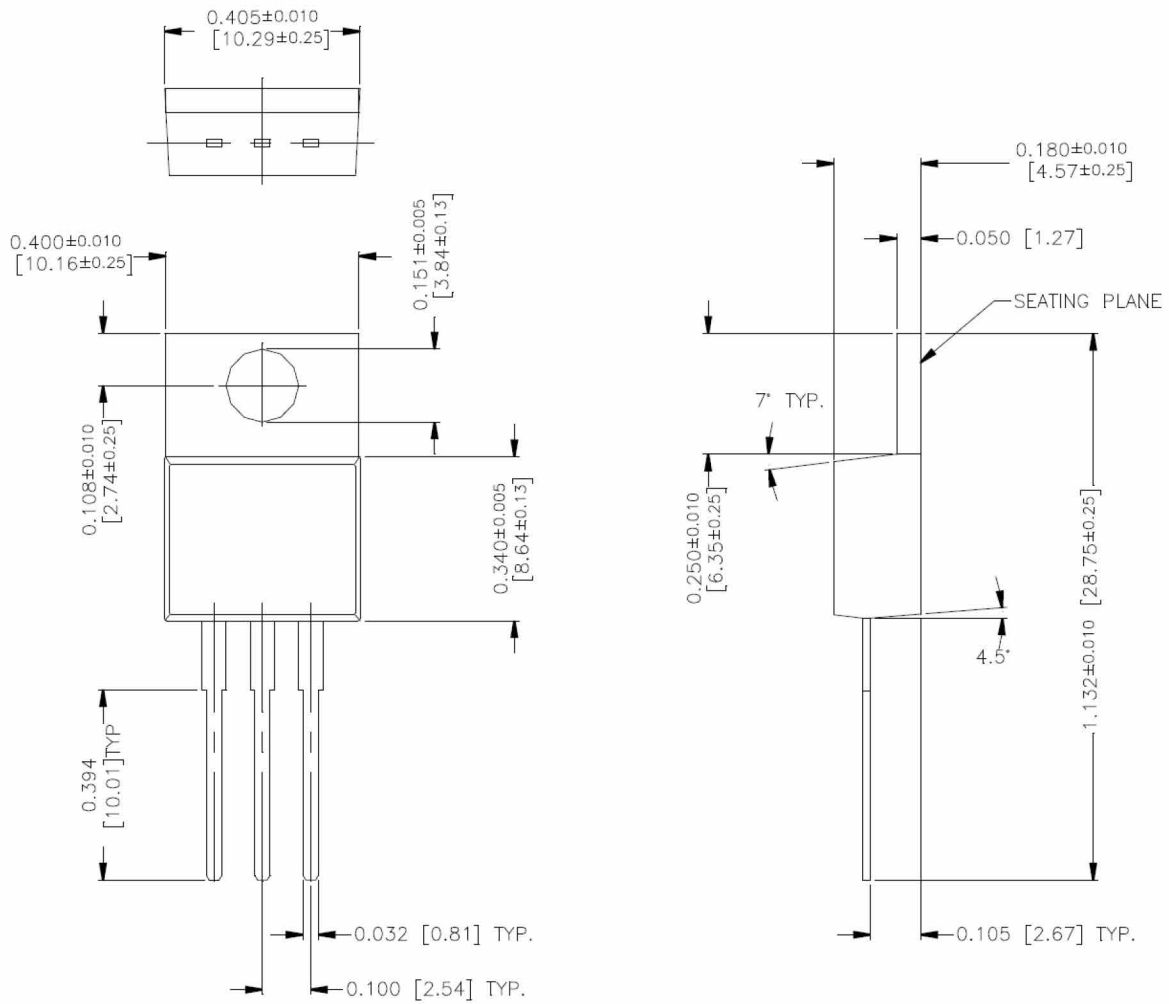

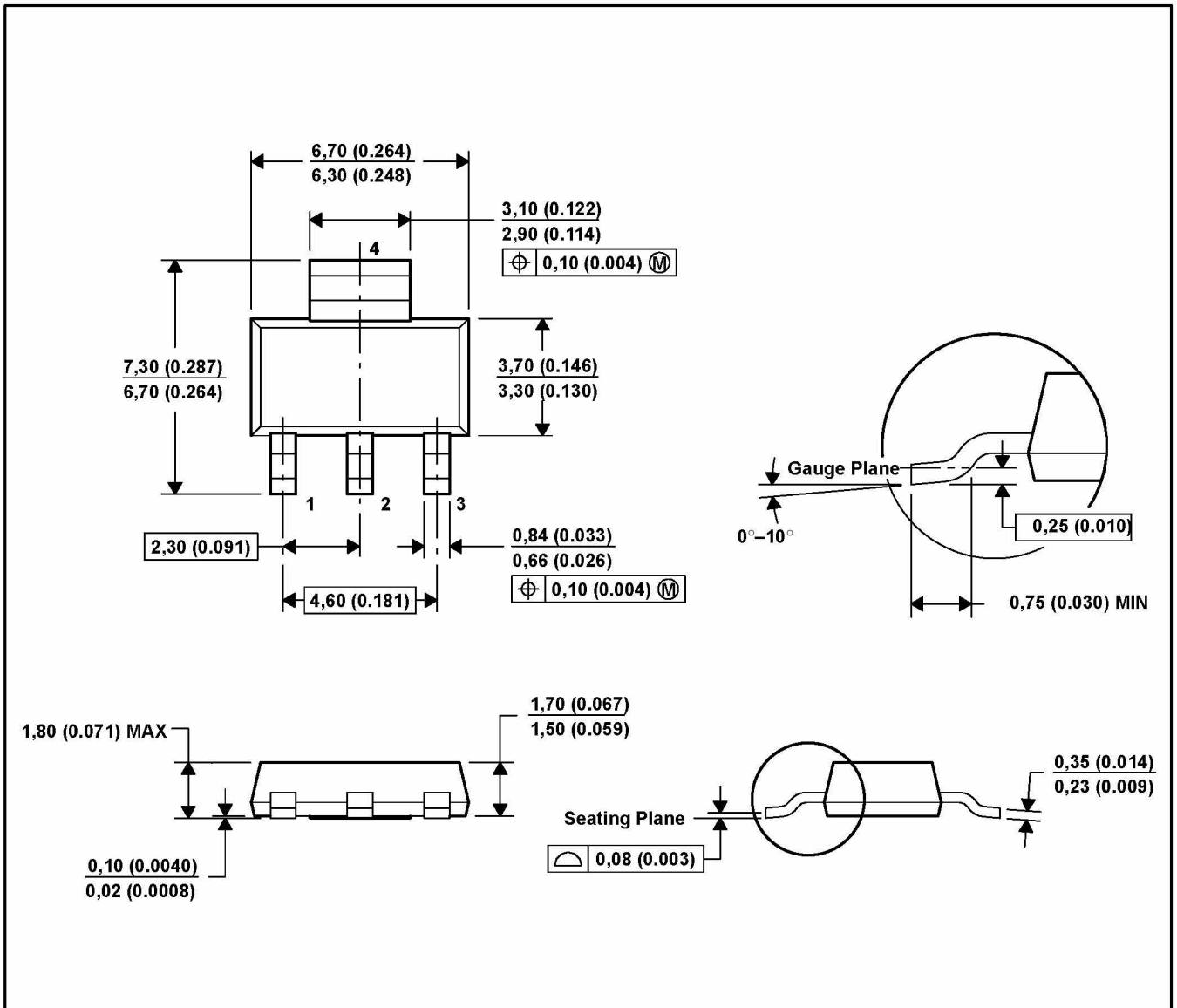
SOT-223 PKG OUTLINE DIMENSIONS

- NOTES:
- All linear dimensions are in millimeters (inches).
 - This drawing is subject to change without notice.
 - Body dimensions do not include mold flash or protrusion.

TO-263-3L PKG OUTLINE DIMENSIONS

