

5A Low Dropout Positive Regulators

Description

The LM1084 series of positive adjustable and fixed regulators are designed to provide 5A with high efficiency. All internal circuitry is designed to operate down to 1.25V input to output differential. On-chip trimming adjusts the reference voltage to 1%. Lm1084 has internal overheat protection and current limiting circuit, which is applicable to all kinds of electronic products.

Features

- Available in 3.3-V, 5.0-V, and Adjustable Versions
- Current Limiting and Thermal Protection
- Output Current 5 A
- Line Regulation 0.015% (Typical)
- Load Regulation 0.1% (Typical)
- Industrial Temperature Range -40°C to 125°C

Applications

- Post Regulator for Switching DC-DC Converter
- High-Efficiency Linear Regulators
- Adjustable Power Supply

Typical Application

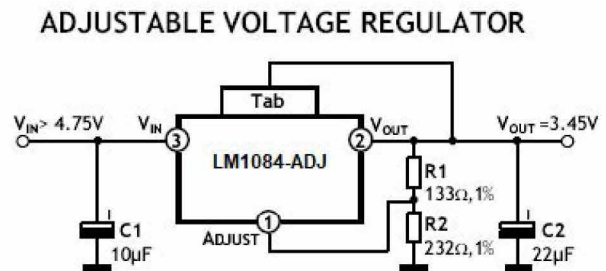
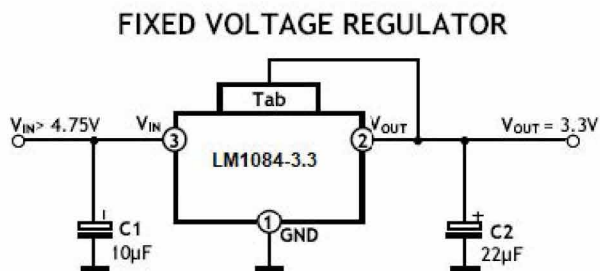

NOTES:

- C1 needed if device is far from filter capacitors
- C2 minimum value required for stability

$$V_{OUT} = V_{REF} \times \left(1 + \frac{R2}{R1}\right) + I_{ADJ} \times R2$$

ORDERING INFORMATION

Part Number	Package	Packing	Temperature(TA)	Package Qty
LM1084ISX-3.3	TO-263-3	Reel	-40°C ~ 125°C	500
LM1084IT-3.3	TO-220-3	Tube	-40°C ~ 125°C	450
LM1084ISX-5.0	TO-263-3	Reel	-40°C ~ 125°C	500
LM1084IT-5.0	TO-220-3	Tube	-40°C ~ 125°C	450
LM1084ISX-ADJ	TO-263-3	Reel	-40°C ~ 125°C	500
LM1084IT-ADJ	TO-220-3	Tube	-40°C ~ 125°C	450

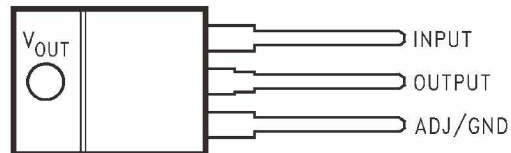
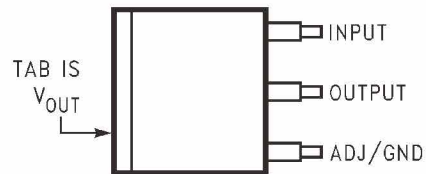
Pin Configuration and Functions
**3-Pin
TO-220 Package
Top View**

**3-Pin
TO-263 Package
Top View**

Pin Functions

PIN		I/O	DESCRIPTION
NAME	NO.		
ADJ/GND	1	-	Adjust pin for the adjustable output voltage version. Ground pin for the fixed output voltage versions.
OUTPUT	2	O	Output voltage pin for the regulator.
INPUT	3	I	Input voltage pin for the regulator.

Absolute Maximum Ratings

over operating free-air temperature range (unless otherwise noted)

	MIN	MAX	UNIT
Maximum Input to Output Voltage Differential			
LM1084-ADJ		29	V
LM1084-3.3		27	V
LM1084-5.0		25	V
Power Dissipation		Internally Limited	
Junction Temperature (T_J)		150	°C
Lead Temperature		260, to 10 sec	°C
Storage temperature, T_{stg}	-65	150	°C

Thermal Information

THERMAL METRIC ⁽¹⁾		LM1084		UNIT
		KTT	NDE	
		3 PINS	3 PINS	
$R_{\theta JA}$	Junction-to-ambient thermal resistance	40.4	22.7	°C/W
$R_{\theta JC(top)}$	Junction-to-case (top) thermal resistance	42.6	15.5	
$R_{\theta JB}$	Junction-to-board thermal resistance	23.0	4.1	
Ψ_{JT}	Junction-to-top characterization parameter	9.8	2.1	
Ψ_{JB}	Junction-to-board characterization parameter	22.0	4.1	
$R_{\theta JC(bot)}$	Junction-to-case (bottom) thermal resistance: Control Section/Output Section	0.65/2.7	0.65/2.7	

Electrical Characteristics

Typicals and limits apply for $T_J = 25^\circ\text{C}$ unless specified otherwise.

	PARAMETER	TEST CONDITIONS	MIN ⁽¹⁾	TYP ⁽²⁾	MAX ⁽¹⁾	UNIT
	Ripple Rejection	$f_{RIPPLE} = 120\text{ Hz}$, $C_{OUT} = 25\text{ }\mu\text{F Tantalum}$, $I_{OUT} = 5\text{ A}$				dB
		LM1084-ADJ, $C_{ADJ} = 25\text{ }\mu\text{F}$, $(V_{IN} - V_O) = 3\text{ V}$, $-40^\circ\text{C} \leq T_J \leq 125^\circ\text{C}$	60	75		
		LM1084-3.3, $V_{IN} = 6.3\text{ V}$, $-40^\circ\text{C} \leq T_J \leq 125^\circ\text{C}$	60	72		
		LM1084-5.0, $V_{IN} = 8\text{ V}$, $-40^\circ\text{C} \leq T_J \leq 125^\circ\text{C}$	60	68		
	Adjust Pin Current	LM1084		55		μA
		LM1084, $-40^\circ\text{C} \leq T_J \leq 125^\circ\text{C}$			120	
	Adjust Pin Current Change	$10\text{ mA} \leq I_{OUT} \leq I_{FULL\ LOAD}$, $1.5\text{ V} \leq V_{IN} - V_{OUT} \leq 25\text{ V}$, $-40^\circ\text{C} \leq T_J \leq 125^\circ\text{C}$		0.2	5	μA
	Temperature Stability	$-40^\circ\text{C} \leq T_J \leq 125^\circ\text{C}$		0.5%		
	Long Term Stability	$T_A = 125^\circ\text{C}$, 1000 Hrs		0.3%	1.0%	
	RMS Output Noise (% of V_{OUT})	$10\text{ Hz} \leq f \leq 10\text{ kHz}$		0.003%		

Electrical Characteristics

 Typical and limits apply for $T_J = 25^\circ\text{C}$ unless specified otherwise.

	PARAMETER	TEST CONDITIONS	MIN ⁽¹⁾	TYP ⁽²⁾	MAX ⁽¹⁾	UNIT
V_{REF}	Reference Voltage	LM1084-ADJ, $I_{OUT} = 10\text{ mA}$, $V_{IN} - V_{OUT} = 3\text{ V}$, $10\text{ mA} \leq I_{OUT} \leq I_{FULL\text{ LOAD}}$, $1.5\text{ V} \leq (V_{IN} - V_{OUT}) \leq 25\text{ V}$ ⁽³⁾	1.238	1.250	1.262	V
		LM1084-ADJ, $I_{OUT} = 10\text{ mA}$, $V_{IN} - V_{OUT} = 3\text{ V}$, $10\text{ mA} \leq I_{OUT} \leq I_{FULL\text{ LOAD}}$, $1.5\text{ V} \leq (V_{IN} - V_{OUT}) \leq 25\text{ V}$ ⁽³⁾ , $-40^\circ\text{C} \leq T_J \leq 125^\circ\text{C}$	1.225	1.250	1.270	
V_{OUT}	Output Voltage ⁽³⁾	LM1084-3.3, $I_{OUT} = 0\text{ mA}$, $V_{IN} = 8\text{ V}$, $0 \leq I_{OUT} \leq I_{FULL\text{ LOAD}}$, $4.8\text{ V} \leq V_{IN} \leq 15\text{ V}$	3.270	3.300	3.330	V
		LM1084-3.3, $I_{OUT} = 0\text{ mA}$, $V_{IN} = 8\text{ V}$, $0 \leq I_{OUT} \leq I_{FULL\text{ LOAD}}$, $4.8\text{ V} \leq V_{IN} \leq 15\text{ V}$, $-40^\circ\text{C} \leq T_J \leq 125^\circ\text{C}$	3.235	3.300	3.365	
		LM1084-5.0, $I_{OUT} = 0\text{ mA}$, $V_{IN} = 8\text{ V}$, $0 \leq I_{OUT} \leq I_{FULL\text{ LOAD}}$, $6.5\text{ V} \leq V_{IN} \leq 20\text{ V}$	4.950	5.000	5.050	V
		LM1084-5.0, $I_{OUT} = 0\text{ mA}$, $V_{IN} = 8\text{ V}$, $0 \leq I_{OUT} \leq I_{FULL\text{ LOAD}}$, $6.5\text{ V} \leq V_{IN} \leq 20\text{ V}$, $-40^\circ\text{C} \leq T_J \leq 125^\circ\text{C}$	4.900	5.000	5.100	
ΔV_{OUT}	Line Regulation ⁽⁴⁾	LM1084-ADJ, $I_{OUT} = 10\text{ mA}$, $1.5\text{ V} \leq (V_{IN} - V_{OUT}) \leq 15\text{ V}$		0.015%	0.2%	
		LM1084-ADJ, $I_{OUT} = 10\text{ mA}$, $1.5\text{ V} \leq (V_{IN} - V_{OUT}) \leq 15\text{ V}$, $-40^\circ\text{C} \leq T_J \leq 125^\circ\text{C}$		0.035%	0.2%	
		LM1084-3.3, $I_{OUT} = 0\text{ mA}$, $4.8\text{ V} \leq V_{IN} \leq 15\text{ V}$		0.5	6	mV
		LM1084-3.3, $I_{OUT} = 0\text{ mA}$, $4.8\text{ V} \leq V_{IN} \leq 15\text{ V}$, $-40^\circ\text{C} \leq T_J \leq 125^\circ\text{C}$		1.0	6	
		LM1084-5.0, $I_{OUT} = 0\text{ mA}$, $6.5\text{ V} \leq V_{IN} \leq 20\text{ V}$		0.5	10	mV
		LM1084-5.0, $I_{OUT} = 0\text{ mA}$, $6.5\text{ V} \leq V_{IN} \leq 20\text{ V}$, $-40^\circ\text{C} \leq T_J \leq 125^\circ\text{C}$		1.0	10	
ΔV_{OUT}	Load Regulation ⁽⁴⁾	LM1084-ADJ, $(V_{IN} - V_{OUT}) = 3\text{ V}$, $10\text{ mA} \leq I_{OUT} \leq I_{FULL\text{ LOAD}}$		0.1 %	0.3%	
		LM1084-ADJ, $(V_{IN} - V_{OUT}) = 3\text{ V}$, $10\text{ mA} \leq I_{OUT} \leq I_{FULL\text{ LOAD}}$, $-40^\circ\text{C} \leq T_J \leq 125^\circ\text{C}$		0.2%	0.4%	
		LM1084-3.3, $V_{IN} = 5\text{ V}$, $0 \leq I_{OUT} \leq I_{FULL\text{ LOAD}}$		3	15	mV
		LM1084-3.3, $V_{IN} = 5\text{ V}$, $0 \leq I_{OUT} \leq I_{FULL\text{ LOAD}}$, $-40^\circ\text{C} \leq T_J \leq 125^\circ\text{C}$		7	20	
		LM1084-5.0, $V_{IN} = 8\text{ V}$, $0 \leq I_{OUT} \leq I_{FULL\text{ LOAD}}$		5	20	mV
		LM1084-5.0, $V_{IN} = 8\text{ V}$, $0 \leq I_{OUT} \leq I_{FULL\text{ LOAD}}$, $-40^\circ\text{C} \leq T_J \leq 125^\circ\text{C}$		10	35	
	Dropout Voltage ⁽⁵⁾	LM1084-ADJ, 3.3, 5, 12, ΔV_{REF} , $\Delta V_{OUT} = 1\%$, $I_{OUT} = 5\text{ A}$, $-40^\circ\text{C} \leq T_J \leq 125^\circ\text{C}$		1.3	1.5	V
I_{LIMIT}	Current Limit	LM1084-ADJ, $V_{IN} - V_{OUT} = 5\text{ V}$, $-40^\circ\text{C} \leq T_J \leq 125^\circ\text{C}$	5.5	8.0		A
		LM1084-ADJ, $V_{IN} - V_{OUT} = 25\text{ V}$, $-40^\circ\text{C} \leq T_J \leq 125^\circ\text{C}$	0.3	0.6		A
		LM1084-3.3, $V_{IN} = 8\text{ V}$, $-40^\circ\text{C} \leq T_J \leq 125^\circ\text{C}$	5.5	8.0		A
		LM1084-5.0, $V_{IN} = 10\text{ V}$, $-40^\circ\text{C} \leq T_J \leq 125^\circ\text{C}$	5.5	8.0		A
	Minimum Load Current ⁽⁶⁾	LM1084-ADJ, $V_{IN} - V_{OUT} = 25\text{ V}$		5	10.0	mA
	Quiescent Current	LM1084-3.3, $V_{IN} = 18\text{ V}$		5.0	10.0	mA
		LM1084-5.0, $V_{IN} \leq 20\text{ V}$		5.0	10.0	mA
	Thermal Regulation	$T_A = 25^\circ\text{C}$, 30 ms Pulse		0.003	0.015	%/W

(1) All limits are specified by testing or statistical analysis.

(2) Typical Values represent the most likely parametric norm.

 (3) $I_{FULLLOAD}$ is defined in the current limit curves. The $I_{FULLLOAD}$ Curve defines the current limit as a function of input-to-output voltage. Note that 30W power dissipation for the LM1084 is only achievable over a limited range of input-to-output voltage.

(4) Load and line regulation are measured at constant junction temperature, and are ensured up to the maximum power dissipation of 30W. Power dissipation is determined by the input/output differential and the output current. ensured maximum power dissipation will not be available over the full input/output range.

(5) Dropout voltage is specified over the full output current range of the device.

(6) The minimum output current required to maintain regulation.

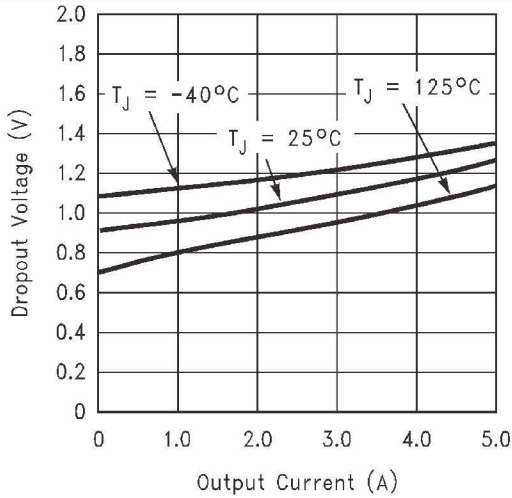
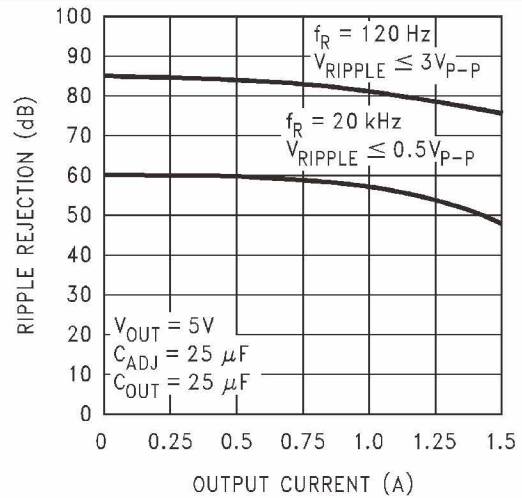
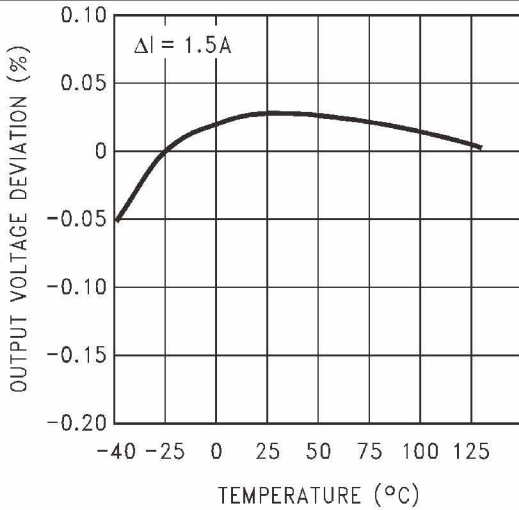
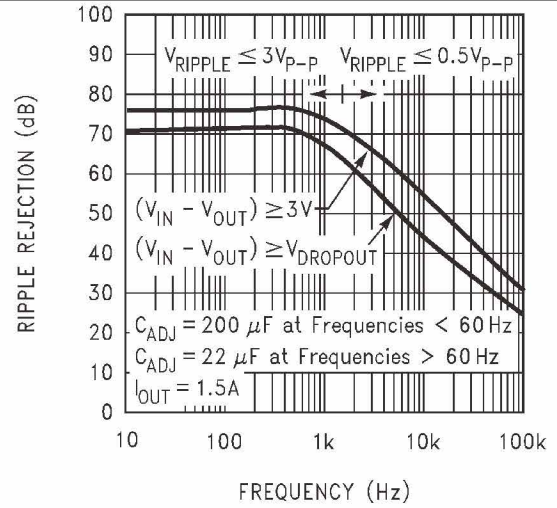
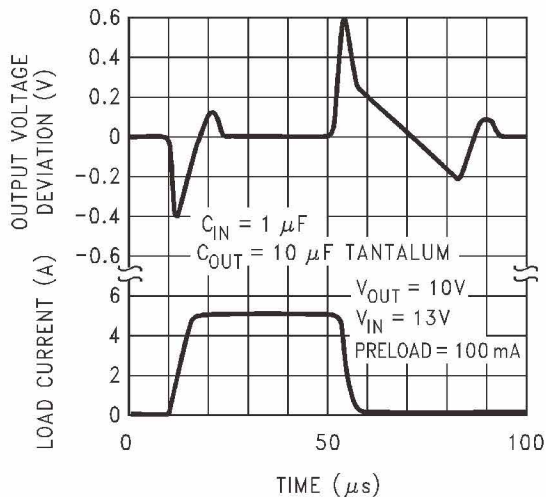
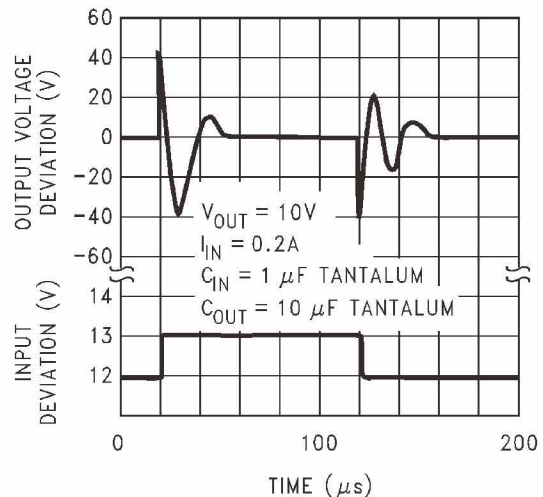
Typical Characteristics

Figure 1. Dropout Voltage ($V_{IN}-V_{OUT}$)

Figure 5. LM1084-ADJ Ripple Rejection vs Current

Figure 3. Load Regulation

Figure 4. LM1084-ADJ Ripple Rejection

Figure 8. LM1084-ADJ Load Transient Response

Figure 9. LM1084-ADJ Line Transient Response

APPLICATION INFORMATION

The LM1084 series of adjustable and fixed regulators are easy to use and have all the protection features expected in high performance voltage regulators: short circuit protection and thermal shut-down.

Pin compatible with older three terminal adjustable regulators, these devices offer the advantage of a lower dropout voltage, more precise reference tolerance and improved reference stability with temperature.

STABILITY

The circuit design used in the LM1084 series requires the use of an output capacitor as part of the device frequency compensation. The addition of 150 μ F aluminum electrolytic or a 22 μ F solid tantalum on the output will ensure stability for all operating conditions.

When the adjustment terminal is bypassed with a capacitor to improve the ripple rejection, the requirement for an output capacitor increases. The value of 22 μ F tantalum or 150 μ F aluminum covers all cases of bypassing the adjustment terminal. Without bypassing the adjustment terminal smaller capacitors can be used with equally good results. To ensure good transient response with heavy load current changes capacitor values on the order of 100 μ F are used in the output of many regulators. To further improve stability and transient response of these devices larger values of output capacitor can be used.

PROTECTION DIODES

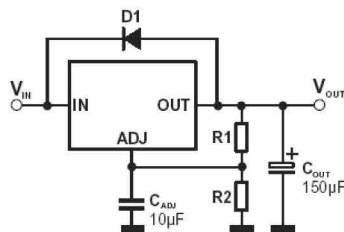

Unlike older regulators, the LM1084 family does not need any protection diodes between the adjustment pin and the output and from the output to the input to prevent over-stressing the die.

Internal resistors are limiting the internal current paths on the LM1084 adjustment pin, therefore even with capacitors on the adjustment pin no protection diode is needed to ensure device safety under short-circuit conditions.

Diodes between the input and output are not usually needed.

Microsecond surge currents of 50A to 100A can be handled by the internal diode between the input and output pins of the device. In normal operations it is difficult to get those values of surge currents even with the use of large output capacitances. If high value output capacitors are used, such as 1000 μ F to 5000 μ F and the input pin is instantaneously shorted to ground, damage can occur. A diode from output to input is recommended, when a crowbar circuit at the input of the LM1084 is used. Normal power supply cycling or even plugging and unplugging in the system will not generate current large enough to do any damage.

The adjustment pin can be driven on a transient basis ± 25 V, with respect to the output without any device degradation. As with any IC regulator, none the protection circuitry will be functional and the internal transistors will break down if the maximum input to output voltage differential is exceeded.

RIPPLE REJECTION

The ripple rejection values are measured with the adjustment pin bypassed. The impedance of the adjust pin capacitor at the ripple frequency should be less than the value of R1 (normally 100 Ω to 120 Ω) for a proper bypassing and ripple rejection approaching the values shown. The size of the required adjust pin capacitor is a function of the input ripple frequency. If R1=100 Ω at 120Hz the adjust pin capacitor should be 25 μ F. At 10 kHz only 0.22 μ F is needed.

The ripple rejection will be a function of output voltage, in circuits without an adjust pin bypass capacitor. The output ripple will increase directly as a ratio of the output voltage to the reference voltage (V_{OUT} / V_{REF}).

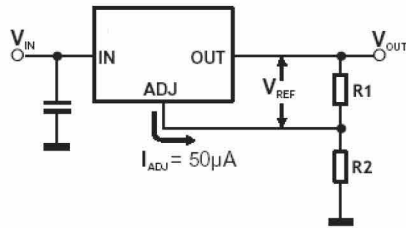
OUTPUT VOLTAGE

The LM1084 series develops a 1.25V reference voltage between the output and the adjust terminal. Placing a resistor between these two terminals causes a constant current to flow through R1 and down through R2 to set the overall output voltage.

This current is normally the specified minimum load current of 10mA. Because I_{ADJ} is very small and constant it represents a small error and it can usually be ignored.

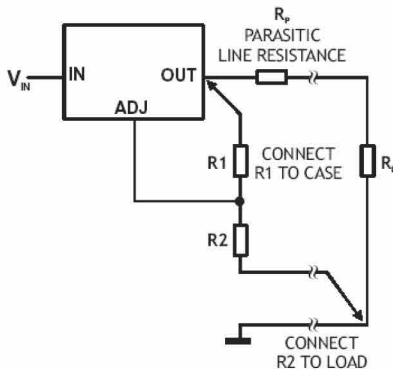
LOAD REGULATION

True remote load sensing it is not possible to provide, because the LM1084 is a three terminal device. The resistance of the wire connecting the regulator to the load will limit the load regulation.

The data sheet specification for load regulation is measured at the bottom of the package. Negative side sensing is a true Kelvin connection, with the bottom of the output divider returned to the negative side of the load.

The best load regulation is obtained when the top of the resistor divider R1 is connected directly to the case not to the load. If R1 were connected to the load, the effective resistance between the regulator and the load would be:

$$\frac{R_p \times (R_2 + R_1)}{R_1}, \quad R_p = \text{Parasitic Line Resistance}$$

Connected as shown, R_p is not multiplied by the divider ratio. Using 16-gauge wire the parasitic line resistance is about 0.004Ω per foot, translating to 4mV/ft at 1A load current. It is important to keep the positive lead between regulator and load as short as possible and use large wire or PC board traces.

THERMAL CONSIDERATIONS

The LM1084 series have internal power and thermal limiting circuitry designed to protect the device under overload conditions. However maximum junction temperature ratings should not be exceeded under continuous normal load conditions.

Careful consideration must be given to all sources of thermal resistance from junction to ambient, including junction-to-case, case-to-heat sink interface and heat sink resistance itself. To ensure safe operating temperatures and reflect more accurately the device temperature, new thermal resistance specifications have been developed. Unlike older regulators with a single junction-to-case thermal resistance specification, the data section for these new regulators provides a separate thermal resistance and maximum junction temperature for both the Control Section and the Power Transistor. Calculations for both temperatures under certain conditions of ambient temperature and heat sink resistance and to ensure that both thermal limits are met.

Junction-to-case thermal resistance is specified from the IC junction to the bottom of the case directly below the die. This is the lowest resistance path for the heat flow. In order to ensure the best possible thermal flow from this area of the package to the heat sink proper mounting is required. Thermal compound at the case-to-heat sink interface is recommended. A thermally conductive spacer can be used, if the case of the device must be electrically isolated, but its added contribution to thermal resistance has to be considered.

Typical Applications
1.2-V to 15-V Adjustable Regulator

This part can be used as a simple low drop out regulator to enable a variety of output voltages needed for demanding applications. By using an adjustable R2 resistor a variety of output voltages can be made possible based on the LM1084-ADJ.

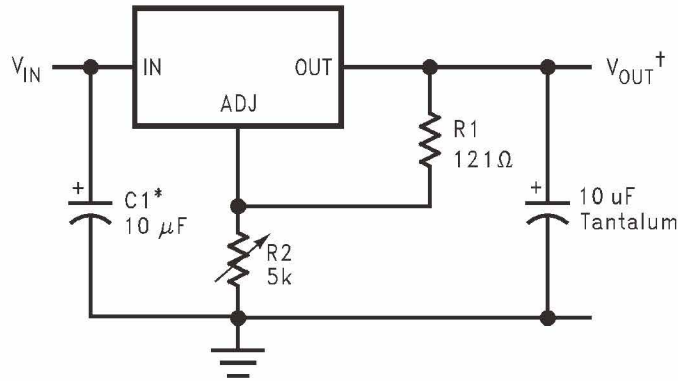

*NEEDED IF DEVICE IS FAR FROM FILTER CAPACITORS

$$^{\dagger}V_{OUT} = 1.25V \left(1 + \frac{R2}{R1}\right)$$

1.2-V to 15-V Adjustable Regulator
Adjustable at 5 V

The application outlines a simple 5 V output application made possible by the LM1084-ADJ. This application can provide 5 A at high efficiencies and very low drop-out.

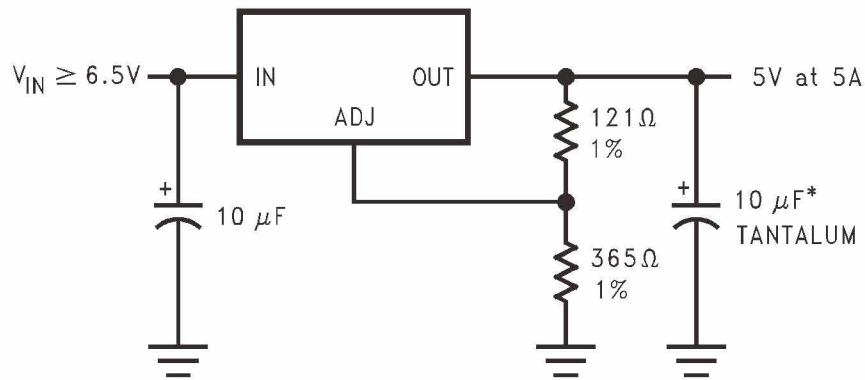

*REQUIRED FOR STABILITY

Adjustable @ 5 V

5-V Regulator With Shutdown

A variation of the 5 V output regulator application with shutdown control based on the is LM1084-ADJ. It uses a simple NPN transistor on the ADJ pin to block or sink the current on the ADJ pin. If the TTL logic is pulled high, the NPN transistor is activated and the part is disabled, outputting approximately 1.25 V. If the TTL logic is pulled low, the NPN transistor is unbiased and the regulator functions normally.

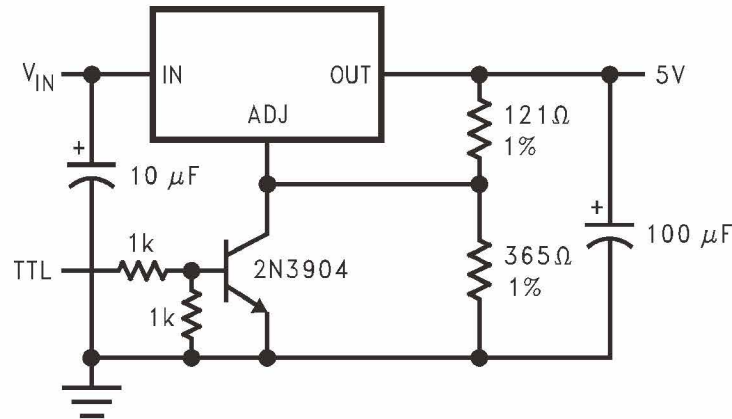

5-V Regulator with Shutdown

Battery Charger

The LM1084-ADJ can be used as a battery charger to regulate the charging current required by the battery bank . In this application the LM1084 acts as a constant voltage, constant current part by sensing the voltage potential across the battery and compensating it to the current voltage. To maintain this voltage, the regulator delivers the maximum charging current required to charge the battery. As the battery approaches the fully charged state, the potential drop across the sense resistor, R_S , reduces and the regulator throttles back the current to maintain the float voltage of the battery.

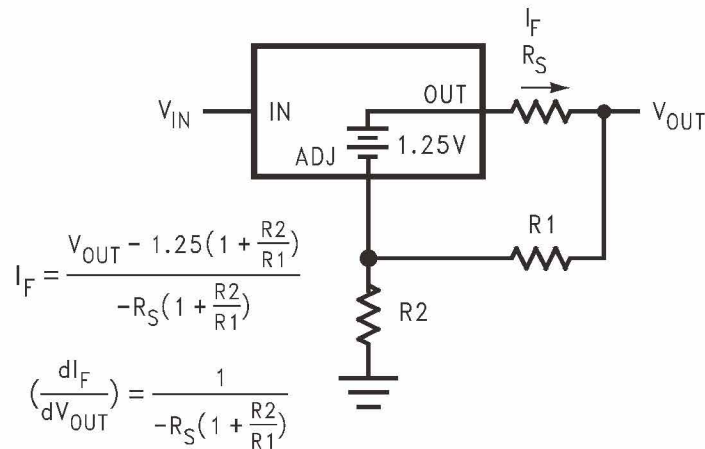

Battery Charger

TO-220 Package

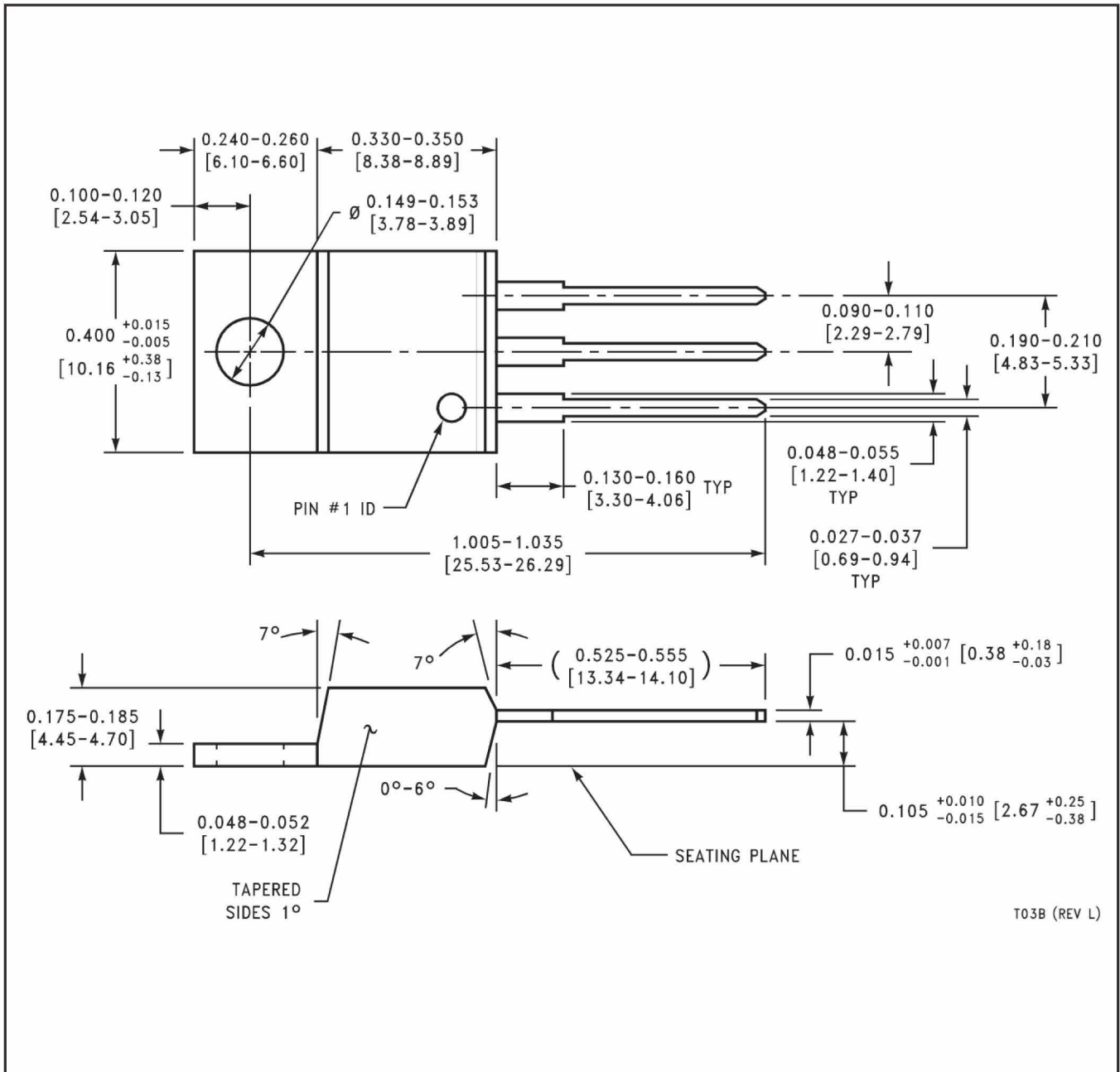

T03B (REV L)

TO-263 Package

